



HD-CCTV DVR



Full HD Digital Video Recorder

HDC400F / HDC400F-PD
HDC801H / HDC801F-PD / HDC1601M
HD1600F-R / HD1600F-PDR

User's Manual
(EN Rev 1.0)

HD-CCTV DVR

Install & User Guide

HD-CCTV DVR Manual.

Thank you for purchasing a Webgate Digital Video Recorder.

Before installation or operation please become familiar with the user manual and other referenced manuals mentioned in the booklet.

User manual, software and hardware described here are protected by copyright by law. With the exception of copying for general use within fair use, copying and reprinting of the user manual, either partially or in entirety, or translating it into any another language without the consent of our Corporate office is strictly prohibited.

Product Warranty and Limited Responsibility

The manufacturer does not assume any responsibility concerning the sale of this product and does not delegate any right to any third party to take any responsibility on its behalf. The product warranty does not cover cases of accidents, negligence, alteration, misuse or abuse. No warranty is offered for any attachments or parts not supplied by the manufacturer.

The manufacturer does not assume any responsibility for followings

- ✓ Malfunctions due to negligence by user
- ✓ Deliberate disassembly and replacement by user
- ✓ Connection of power source other than a properly rated power source
- ✓ Malfunctions caused by natural disasters (fire, flood, tidal wave, etc)
- ✓ The warranty period for HDD is one year
- ✓ Any data damage due to HDD damage

The product is not for exclusive use of crime prevention but for assistance in cases as fire or theft. We take no responsibility for damage from any incident.



This equipment has been tested and found to comply with the limits for a Class A digital device, pursuant to part 15 of the FCC Rules. These limits are designed to provide reasonable protection against harmful interference when the equipment is operated in a commercial environment.

This equipment generates, uses, and can radiate radio frequency energy and, if not installed and used in accordance with the instruction manual, may cause harmful interference to radio communications. Operation of this equipment in a residential area is likely to cause harmful interference in which case the user will be required to correct the interference at his own expense.



Correct Disposal of This Product (Waste Electrical & Electronic Equipment)

(Applicable in the European Union and other European countries with separate collection systems)

This marking on the product, accessories or literature indicates that the product and its electronic accessories (e.g. charger, headset, USB

cable) should not be disposed of with other household waste at the end of their working life. To prevent possible harm to the environment or human health from uncontrolled waste disposal, please separate these items from other types of waste and recycle them responsibly to promote the sustainable reuse of material resources.

Household users should contact either the retailer where they purchased this product or their local government office, for details of where and how they can take these items for environmentally safe recycling.

Business users should contact their supplier and check the terms and conditions of the purchase contract. This product and its electronic accessories should not be mixed with other commercial wastes for disposal.



Correct disposal of batteries in this product

(Applicable in the European Union and other European countries with separate battery return systems.)

This marking on the battery, manual or packaging indicates that the batteries in this product should not be disposed of with other household waste at the end of their working life. Where marked, the chemical symbols Hg, Cd or Pb indicate that the battery contains mercury, cadmium or lead above the reference levels in EC Directive 2006/66. If batteries are not properly disposed of, these substances can cause harm to human health or the environment.

To protect natural resources and to promote material reuse, please separate batteries from other types of waste and recycle them through your local, free battery return system.

Copyright ©2013 WEBGATE. All rights reserved.

Introduction

Warning

Warning

- ✓ Please do not bend or press power cord by force which could lead to fire.
- ✓ Be careful not to pull or plug with wet hands to avoid fire or electric shock.
- ✓ In case of changing built-in lithium battery, it should be replaced with same brand or similar one to prevent a danger of explosion. Since old batteries could be a factor of environment contamination, please disposed of them properly.
- ✓ Do not throw the batteries in fire or heating units. Neither short circuit nor disassembly is prohibited.
- ✓ Do not recharge battery used for remote controller.
- ✓ Do not open the top cover otherwise it could lead to electric shock and product damage.
- ✓ The previous recorded data is deleted if record continues when HDD is full so please check disk setup status.
- ✓ Manufacturer takes no responsibility for any damaged data due to customer's carelessness or negligence.

A-rated device(Broadcasting Communication Equipment for business use only)

Users/Sellers should under this is A-rated device for business use only and it must not be used outside of family.

Caution

- ✓ Do not place heavy objects on top of the product.
- ✓ Product is for indoor use only and it is not water or damp proof. Use product to its environmental specifications (Temperature & Humidity). To clean the product, gently wipe the outside with a clean dry cloth.
- ✓ Product uses AC power of 110V ~ 240V. Be cautious not to cause electric damages to the product.
- ✓ Be careful not to drop the product. Physical shocks may harm the product including internal HDD. In addition, please do not throw or drop it.
- ✓ Product is made of metal you can hurt another human if you throw or used as a weapon. Keep away from the reach of children and install in a safe place.
- ✓ If Product does not operate properly, please contact the closest WEBGATE distributor for service. Tampering or disassembling the product will void the warranty.
- ✓ The product can transmit real time video over network or internet and can be used for monitoring purpose depending on installation sites. So please check and review related regulations before installation.

Experience and technical skills are needed for the installation of this product. Improper installation may cause fire, electric shocks, or defects. Contact the nearest Webgate dealer for installations.

Contents of the manual can differ according to firmware or Software upgrade, and the appearance of products may be changed for the improvement of quality without an advance notice

◆ System power off

In case user turn off device by force while device is working, it could give damage on HDD and device so please turn off device safely using power button located in the front panel. You should install a UPS system for safe operation in order to prevent damage caused by an unexpected power failure.

◆ Working Temperature

The working temperature of the product is 5°C~45°C or 41°F~113°F. DVR may not work properly if left in low temperature for a long period of time. If such is the case, then store at room temperature for some time before using it again.

Contents

Introduction 2

Warning 2

Key Features 5

Components 7

Product Description 9

Installation 19

Connecting other devices 22

Usage 29

Default setting 30

Menu usage 35

Menu structure 35

FUNC menu 35

Monitoring 35

Search and playback 39

Playback 39

Screen composition/names of the functions 40

Copy 42

configuration 43

system configuration 43

Disk 44

Network 50

Device settings 53

Event Configuration 56

Recording set up 61

Web Viewer 64

System requirement 64

installation 64

login 64

User set up 64

Monitor 65

Playback 68

JAVA Viewer 71

Mobile Viewer 71

appendix 72

problem solving [FAQ] 72
compatible HDD 74
Factory default set-up values 74
Product specification 78
Product Dimension 85

Key Features

FULL HD

This product supports live monitoring, recording, playback of HD-SDI video of 1080p(1920x1080). Records 5 seconds before an event and records up to 30fps per channel.

HD-SDI video record

- HD 1080p : 480fps recording
- ✓ Supports manual & schedule recording at all times.
- ✓ Supports archiving event list(sensor, video loss, motion detection, Text)
- ✓ Max 5 seconds pre-alarm recording per each channel

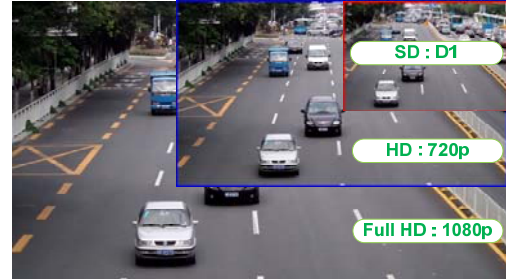

FULL HD high quality video shows far superior resolution than SD video product. Over 1200 TV lines at 1080p resolution can be visible.

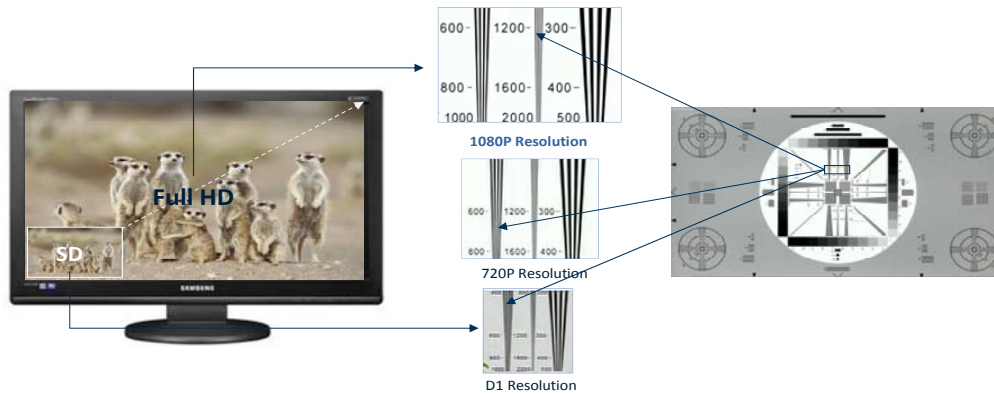

HD-SDI

The product can transfer HD (High-Definition) signal image using HD-SDI technology via coax cable. Please be noted that this product doesn't accept SD signal. The supportable resolution is as below.

- ✓ Transmission Method - SMPTE 292M : HD-SDI
- ✓ Resolution - SMPTE 274M : 1920x1080p 25/30Hz

PoC (Power over Coax) *

Supplies power to PoC Camera via Coaxial cable.

Connect Webgate's PoC camera & PoC adapter to DVR to supply power to PoC camera through a coaxial cable without extra power supplies.

CoC (Control over Coax) *

Via CoC Function, PoC can be controlled by a coaxial cable.

With CoC function, Webgate's PoC camera can control PoC camera via coaxial cable from DVR without RS-485 cable.

DoubleReach™ (Enhances transmission distance by Max. 400m) *

It is a technology that increases transmission distance by 400m for HD-SDI cameras.

Connect Webgate's DR101P-TX to HD-SDI camera to transmit HD-SDI video to a location 400m away and to use the camera through DR port(odd channel) on DVR.

* Varies between different models

RAID 1/5/10 Levels *

Supports RAID.

Via RAID MANAGER, various RAID Levels can be configured without additional RAID devices.(RAID 1/5/10)

Surveillance Screens

Every channel will display HD streams without interruptions and will offer many different types of screens.

- ✓ Various Surveillance Screen Mode - Single, Multi Screens (1,4,9,10,13,16,CustomA,B,C) *
- ✓ Auto Screen Sequence
- ✓ Event Pop-up

Voice Recording

Supports real time voice input and recording function.

- ✓ Real time 4ch voice input and recording function
- ✓ Input : 4ch RCA, Output : 1ch RCAI(Rear), 1ch HDMI(Rear)
- ✓ Audio recording and playback can be played Simultaneously

Search and Playback

Various useful functions for search & playback

- ✓ Simultaneous playback for every channel
- ✓ Playback by time, date, channel
- ✓ Time/ Calendar/Event search
- ✓ Forward/backward search function of a freeze frame

Save and Backup

You can record video data into the internal HDD, and image can be copied to a USB memory.

- ✓ Backup device : USB stick
- ✓ External storage device : e-SATA HDD or NS0104R(exclusive storage device) *

Network

Supports LAN, xDSL, and etc., and key functions can easily be controlled by web browser or customized CMS program.

- ✓ HD Live monitoring/playback/backup from the remote site
- ✓ Multi-streaming feature for slow network environment (supports nHD monitoring)
- ✓ Sending event info(image) using E-Mail/ FTP
- ✓ Recorded video playback, save, search function, and DVR control function on PC via CMS
- ✓ Supports 10/100/1000 Mbps Ethernet/xDSL
- ✓ Managing up to 1024 DVRs with CMS

Others



- ✓ User friendly GUI and mouse
- ✓ Easy and simple firmware upgrade, and recorded video back up function using USB stick
- ✓ Using Ac the PC Playback function, replay the DVR's HDD on a PC
- ✓ Supports PTZ control and PRESET function
- ✓ Easy control of up to 255 DVR with a single remote control

* Varies between different models



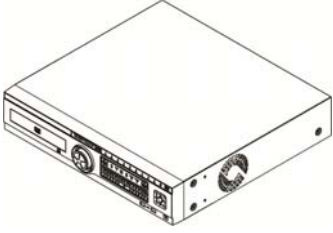
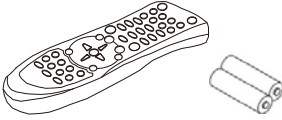
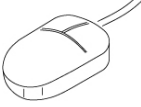
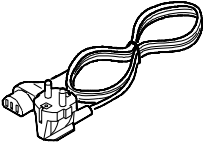
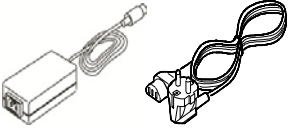
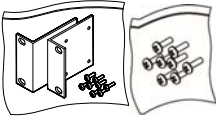

Components

Please check the below to make sure you have every part.

HD1600F-PDR / HD1600F-R

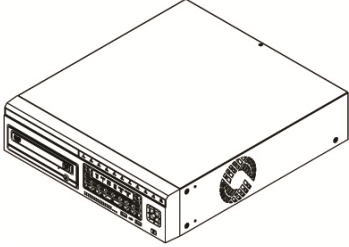
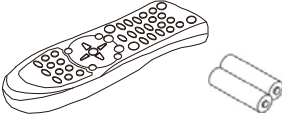
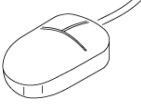
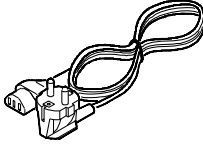
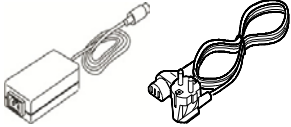



			
DVR	Remote Control & Batteries	Mouse	power cord
			
PoC adaptor (*)	Rack Bracket & Screws	SW & user guide CD	Installation and user guide Quick installation guide

HDC1601M / HDC801F-PD / HD801H

			
DVR	Remote Control & Batteries	Mouse	power cord
			
PoC adaptor (*)	Rack Bracket & Screws	SW & user guide CD	Installation and user guide Quick installation guide

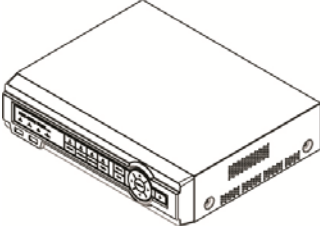
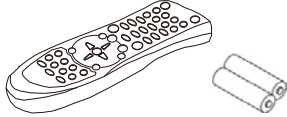
* Only available in PoC models

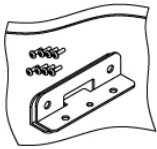
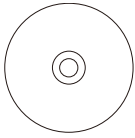
HDC400F-PD / HDC400F

			
<p>DVR</p>	<p>Remote Control & Batteries</p>	<p>Mouse</p>	<p>adaptor & power cord</p>
			
<p>Rack Bracket & Screws</p>	<p>SW & user guide CD</p>	<p>Installation and user guide Quick installation guide</p>	

Product Description

HD1600F-PDR / HD1600F-R

Front view

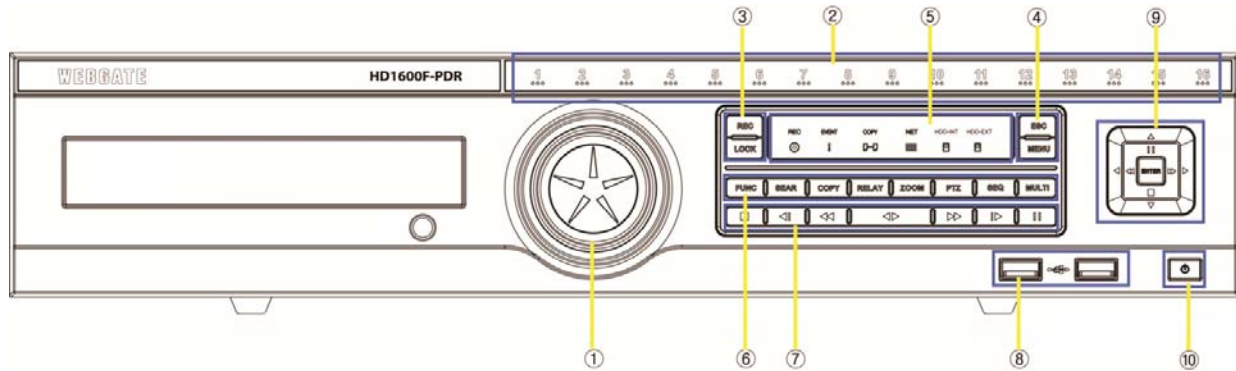

part name	function description
1	Jog shuttle Use to control fast forward/rewind FPS rate.
2	touch channel button Touch to select channels from live-streams and playback list.
3	channel LED Shows input status of a stream and event movement status.
4	REC Starts and pauses the manual recording
5	LOCK Locks screen control button on monitoring mode to prevent from use
6	ESC Exits current menu or cancels the selected
7	MENU Enters the Main Menu where every setting of the DVR is possible
8	Record indicator Shows the recording status when the DVR is recording
9	Event indicator Will be turned if event happens.
10	Copy indicator Turns off when copy begins to show the copy progress
11	Network indicator Turns off when network is connected to shows the network connection status
12	Built-in HDD indicator Turns off while built-in HDD records
13	external HDD indicator Turns off while recording about eSATA HDD is in process
14	FUNC button runs func menu on which users can access to main menu, multi monitor screens, auto screen sequence, auto screen switch, copy, search, playback, keylock, log out and power
15	SEAR button Runs a menu with time/calendar/event search function.
16	COPY button Runs a menu with AVI, EXE file copy function via USB stick
17	RELAY button Manually sets Relay On/Off
18	ZOOM button Enters digital zoom mode where 16 times magnification under live/playback single screen and movement on magnified picture are possible.
19	SEQ button Runs auto screen sequence mode for multi/single screens under live mode up to 16 channels.
20	MULTI button Changes multi-screen mode under live & playback mode.
21	■(STOP) Stops the playback and exits to the live mode
22	◀I(SREW) Playback Rewind at 1Frame
23	◀◀(REW) Changes the speed of rewind playback
24	▶▶(PLAY) Begins the playback
25	▶▶(FWD) Changes the speed of fast forward playback
26	I▶(SFWD) Playback fast forward at 1Frame
27	(PAUSE) Temporarily pauses the playback
28	USB port USB port for flash memory or mouse.
29	◀(move to left) Move to left on menu
30	▶(move to right) Move to right on menu
31	▲(move up) increases values on menu
32	▼(move down) decreases values on menu
33	Enter(select) Move to submenu on menu or select an item
34	Power turns ON/OFF the power

HD1600F-PDR

Rear view

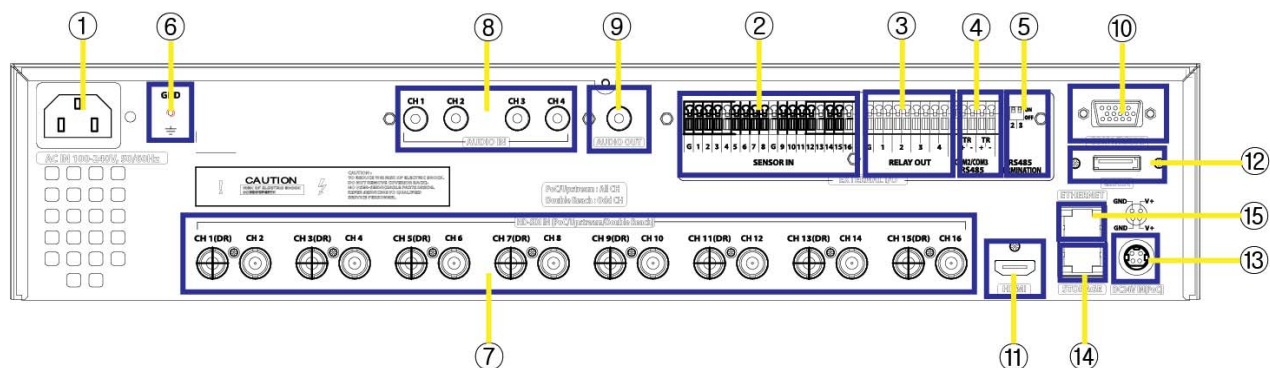

No	input/output terminal name	function
1	Power In	AC100V~AC240V power cord socket.
2	Sensor IN	External sensor input terminal
3	Relay	Relay connect terminal
4	COM2,3	Connct RS-485
5	RS-485 terminating resistors	Set terminating resistors when using RS-485 method
6	Ground connection	Connection terminals that connects DVR to an outside device
7	Channel input	Input connection terminal for BNC of a HD-SDI camera
8	Audio input	Audio input connect terminal.
9	Audio output	Speaker output terminal.
10	COM1	RS-232C D-SUB.
11	HDMI Output	Output port on which HDMI monitor can be connected
12	eSATA port	eSATA external HDD is connected
13	DC 24V PoC	PoC adaptor is connected
14	Storage	Exclusive network storage device(NS0104R) is connected and used
15	ethernet	network connecting terminal (RJ-45)

HD1600F-R

Rear view

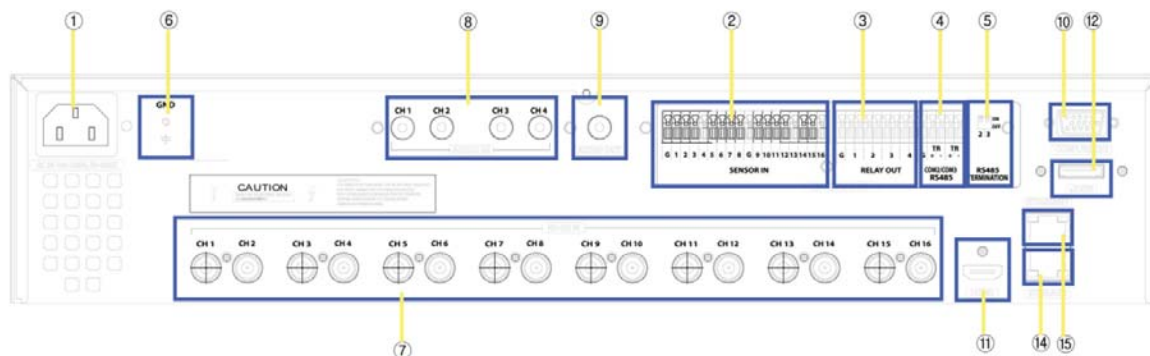

No	input/output terminal name	function
1	Power In	AC100V~AC240V power cord socket.
2	Sensor IN	External sensor input terminal
3	Relay	Relay connect terminal
4	COM2,3	Connct RS-485
5	RS-485 terminating resistors	Set terminating resistors when using RS-485 method

No	input/output terminal name	function
6	Ground connection	Connection terminals that connects DVR to an outside device
7	Channel input	Input connection terminal for BNC of a HD-SDI camera
8	Audio input	Audio input connect terminal.
9	Audio output	Speaker output terminal.
10	COM1	RS-232C D-SUB.
11	HDMI Output	Output port on which HDMI monitor can be connected
12	eSATA port	eSATA external HDD is connected
13	N/A	
14	Storage	Exclusive network storage device(NS0104R) is connected and used
15	ethernet	network connecting terminal (RJ-45)

HDC1601M / HDC801F-PD / HDC801H

Front view

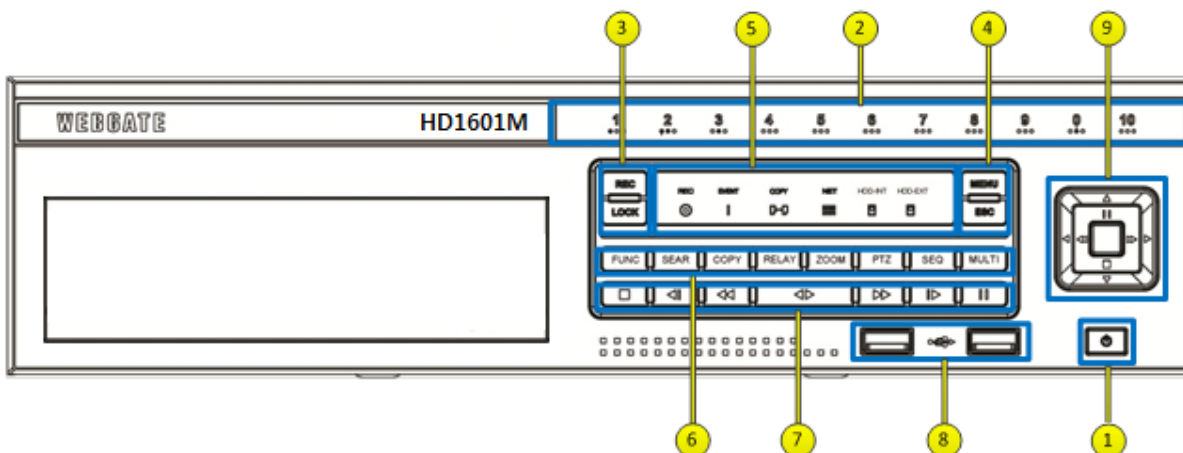

Category		Function
1	Power	To turn On/Off power
2	Touch channel button	Select channel by touch during live and playback.
	Channel LED	Shows image input status and event working status.
3	REC	To start and stop Manual record
	LOCK	To lock the buttons on the front panel/remote controller in monitoring status
4	ESC	Exits current menu or cancels the selected
	MENU	To enter Menu
5	Record LED	Display recording status
	Event LED	Display event status when event is triggered.
	Copy LED	Display copy status once copy is under process by flickering
	Network LED	Display network connection status by flickering
	Internal HDD LED	It flickers while internal HDD is recording
	ExternalHDD LED	It flickers while eSATA HDD is recording
6	FUNC button	Runs FUNC menu where user can use main menu, screen division, auto sequence, copy, search, playback, keylock, logout, poweroff
	SEAR button	Runs menu for search by time, calendar, event, thumbnail
	COPY button	Runs menu for copy AVI, EXE thru DDVD, USB
	RELAY button	Runs Relay On/Off manually
	ZOOM button	Max 16 times zoon in live/playback screen and get into digital zoom mode
	SEQ button	Runs Max 16 scenario of auto sequence in live mode
7	MULTI button	Changes division mode in live and playback mode
	■(STOP)	Stop playback
	◀I(SREW)	To move to reverse direction by one frame
	◀◀(REW)	To move or select in menu and change replay speed to reverse direction in playback mode.
	◀▶(PLAY)	To select playback mode and change playback direction.
	▶▶(FWD)	To move or select in menu and change replay speed to forward direction in playback mode.
	I▶(SFWD)	To move to forward direction by one frame
II(PAUSE)	Pause playback	
8	USB port	USB Memory, USB connection port
	◀(Left move)	To move to left in menu
	▶(Right move)	To move to right in menu.
9	▲(Upper move)	To move to upper in menu
	▼(Down move)	To move to lower in menu.
	Enter(select)	To select menu or enter the selected menu

HDC1601M

Rear view

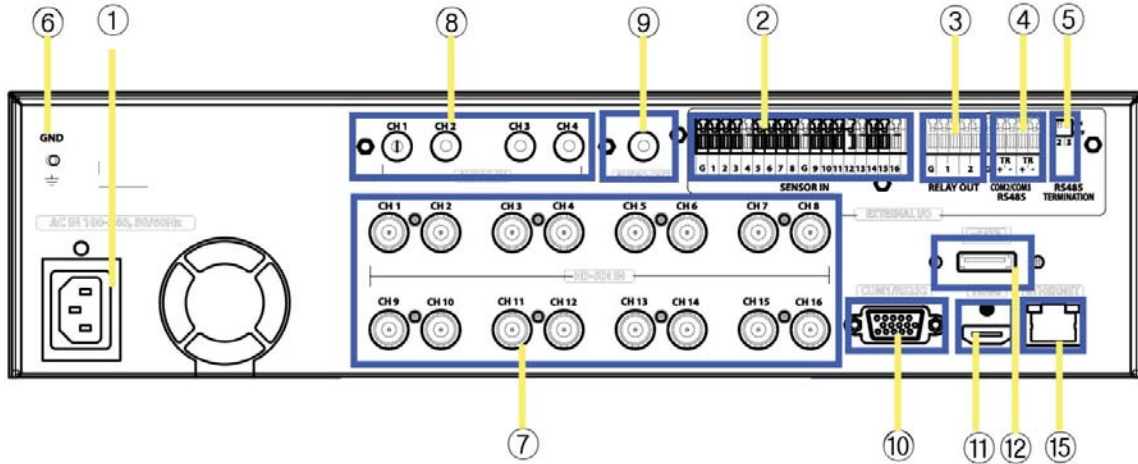

No	input/output terminal name	function
1	Power In	AC100V~AC240V power cord socket.
2	Sensor IN	External sensor input terminal
3	Relay	Relay connect terminal
4	COM2,3	Connct RS-485
5	RS-485 terminating resistors	Set terminating resistors when using RS-485 method
6	Ground connection	Connection terminals that connects DVR to an outside device
7	Channel input	Input connection terminal for BNC of a HD-SDI camera
8	Audio input	Audio input connect terminal.
9	Audio output	Speaker output terminal.
10	COM1	RS-232C D-SUB.
11	HDMI Output	Output port on which HDMI monitor can be connected
12	eSATA port	eSATA external HDD is connected
13	N/A	
14	N/A	
15	ethernet	network connecting terminal (RJ-45)

HDC801F-PD

Rear view

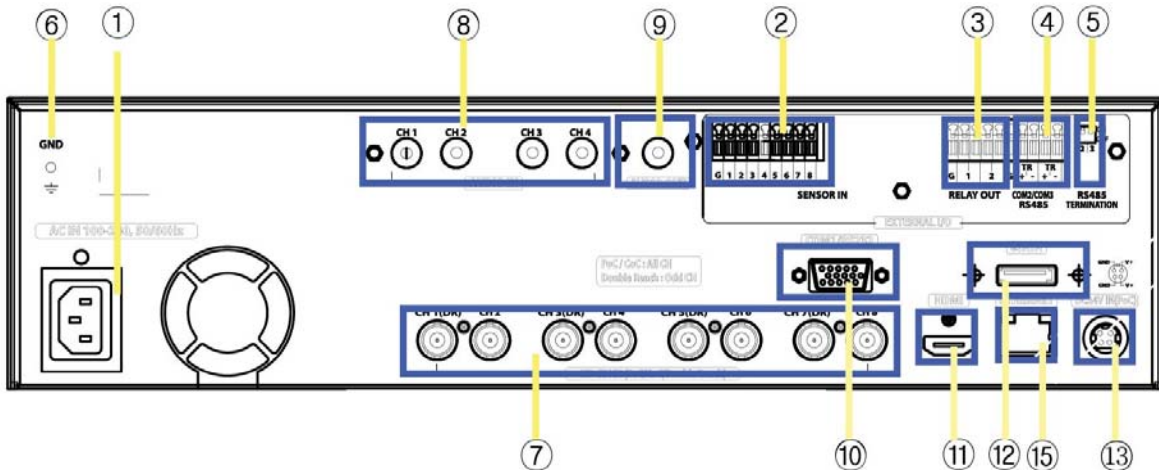

No	input/output terminal name	function
1	Power In	AC100V~AC240V power cord socket.
2	Sensor IN	External sensor input terminal

No	input/output terminal name	function
3	Relay	Relay connect terminal
4	COM2,3	Connct RS-485
5	RS-485 terminating resistors	Set terminating resistors when using RS-485 method
6	Ground connection	Connection terminals that connects DVR to an outside device
7	Channel input	Input connection terminal for BNC of a HD-SDI camera
8	Audio input	Audio input connect terminal.
9	Audio output	Speaker output terminal.
10	COM1	RS-232C D-SUB.
11	HDMI Output	Output port on which HDMI monitor can be connected
12	eSATA port	eSATA external HDD is connected
13	DC 24V PoC	PoC adaptor is connected
14	N/A	
15	ethernet	network connecting terminal (RJ-45)

HDC801H

Rear view

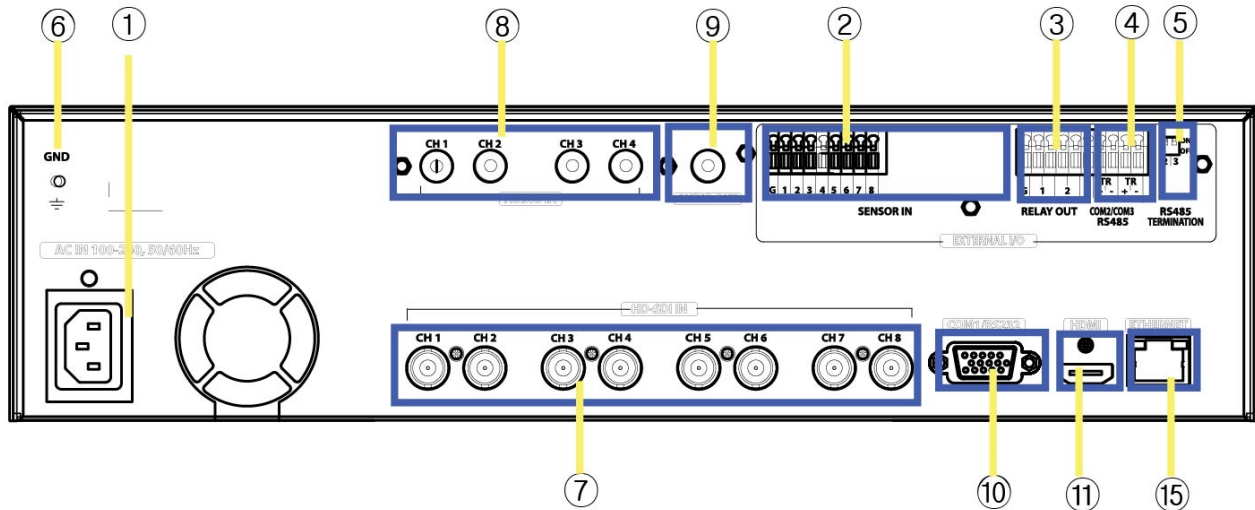

No	input/output terminal name	function
1	Power In	AC100V~AC240V power cord socket.
2	Sensor IN	External sensor input terminal
3	Relay	Relay connect terminal
4	COM2,3	Connct RS-485
5	RS-485 terminating resistors	Set terminating resistors when using RS-485 method
6	Ground connection	Connection terminals that connects DVR to an outside device
7	Channel input	Input connection terminal for BNC of a HD-SDI camera
8	Audio input	Audio input connect terminal.
9	Audio output	Speaker output terminal.
10	COM1	RS-232C D-SUB.
11	HDMI Output	Output port on which HDMI monitor can be connected
12	N/A	
13	N/A	
14	N/A	
15	ethernet	network connecting terminal (RJ-45)

HD400F-PD / HD400F

Front view

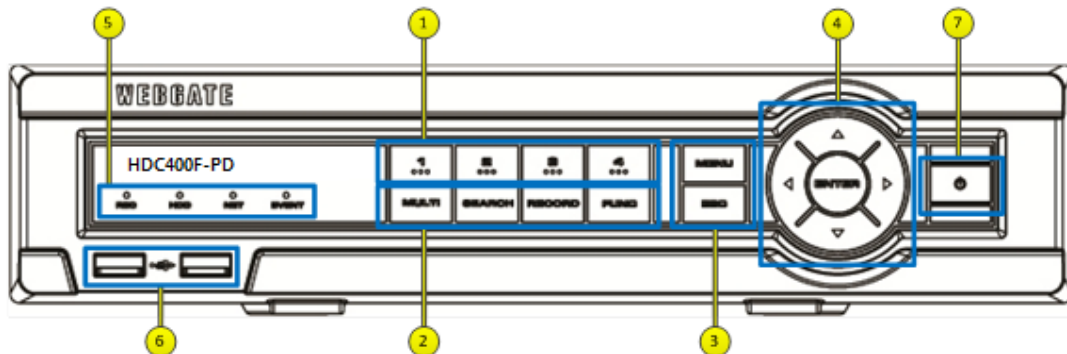

Category	Function	
1	Touch channel button Channel LED MULTI button SEAR button	Select channel by touch during live monitoring and playback. Shows video input status and event working status. Changes split screen mode during live monitoring and playback Open Search menu that supports Time, Calendar, Event, Thumbnail search
2	REC button FUNC button	It starts and stops Manual recording Open FUNC menu that handles main menu, screen split, auto sequence, copy, search, playback, keyLock, logout, and power off
3	ESC MENU	Exits current menu or cancels the selected Enters main menu
4	◀(Left move) ▶(Right move) ▲(Up move) ▼(Down move) ENTER(Select)	Moves to left item at menu (changes replay speed during reverse playback) Moves to right item at menu (changes replay speed during forward playback) Increase values at menu (pauses the playback) Decrease values at menu (stops playback and return to live monitoring) Enter sub-menu (starts playback)
5	Record LED HDD LED Network LED Event LED	Shows recording status by flickering Shows HDD working by flickering Shows network connection status by flickering It turns on if an event is triggered
6	USB port	USB port for flash memory or mouse
7	Power	Turns On and Off DVR power

HD400F-PD

Rear view

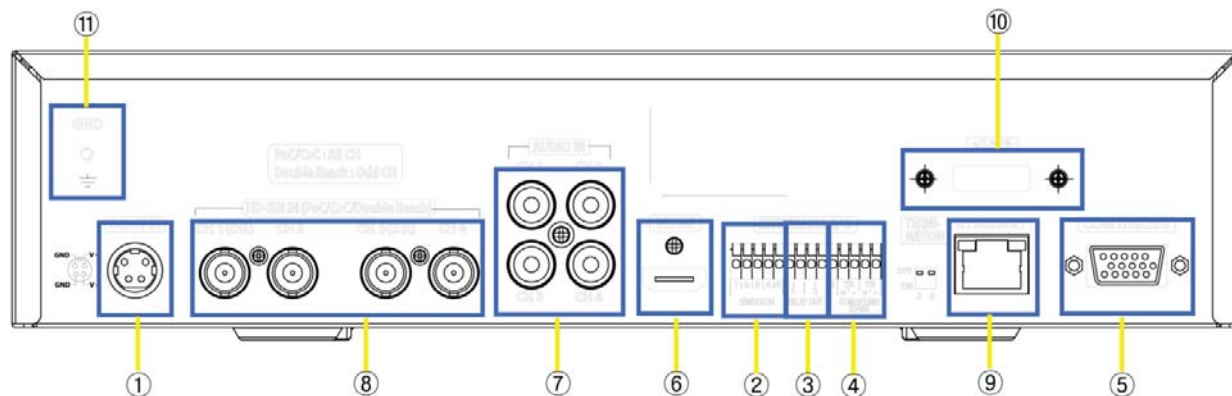

No	In/Out port name	Function
1	Power input	Connector for power input
2	Sensor IN	Input for external sensor.

No	In/Out port name	Function
3	Relay	Relay Connection terminal.
4	COM2	RS-485 device connection
5	COM1	D-SUB connector for RS-232C
6	HDMI	Video output HDMI connector for monitor
7	AUDIO IN	RCA connection for Audio input
8	HD-SDI IN	BNC connectors for camera input
9	ETHERNET	RJ45 connector for network
10	eSATA	eSATA connector for external storage
11	GND	Ground between DVR & external device.

HD400F

Rear view

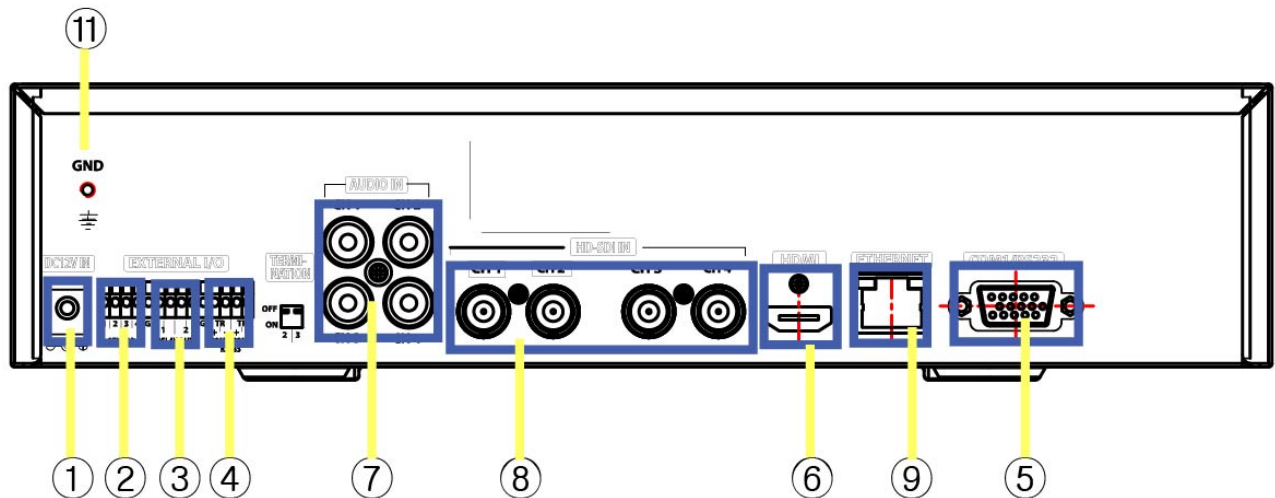

No	In/Out port name	Function
1	Power input	Connector for power input
2	Sensor IN	Input for external sensor.
3	Relay	Relay Connection terminal.
4	COM2	RS-485 device connection
5	COM1	D-SUB connector for RS-232C
6	HDMI	Video output HDMI connector for monitor
7	AUDIO IN	RCA connection for Audio input
8	HD-SDI IN	BNC connectors for camera input
9	ETHERNET	RJ45 connector for network
10	N/A	
11	GND	Ground between DVR & external device.

Remote control

Can use every function of the DVR and control several DVRs with only one remote control. To be able to use the remote control, please create a user ID on the remote control ID section of system settings. (See the right picture for working angle of a remote control)

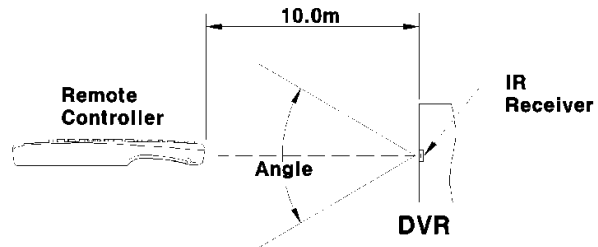

Horizontal Angle : $\pm 30^\circ$
Vertical Angle : $\pm 30^\circ$

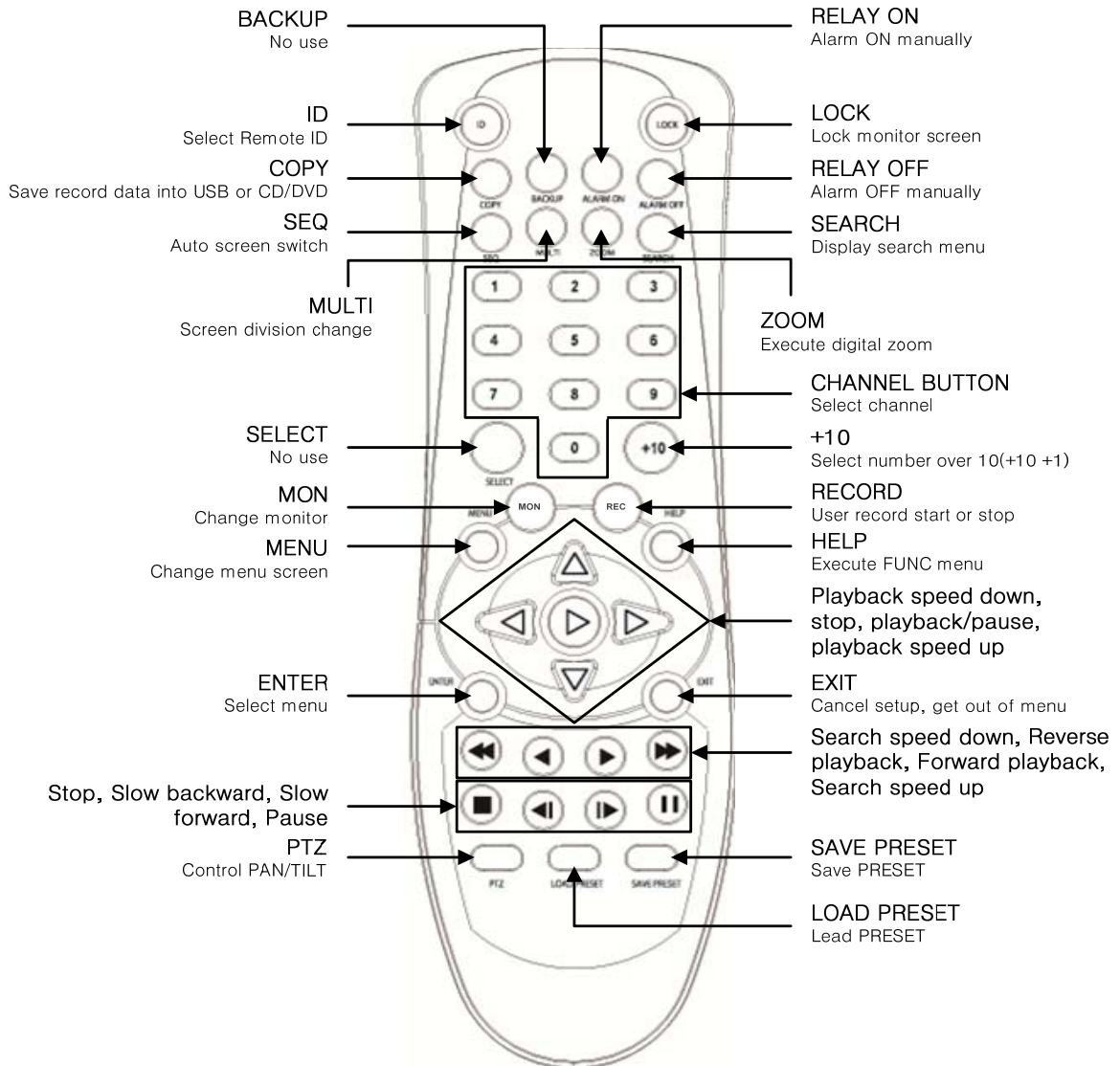

Remote control A

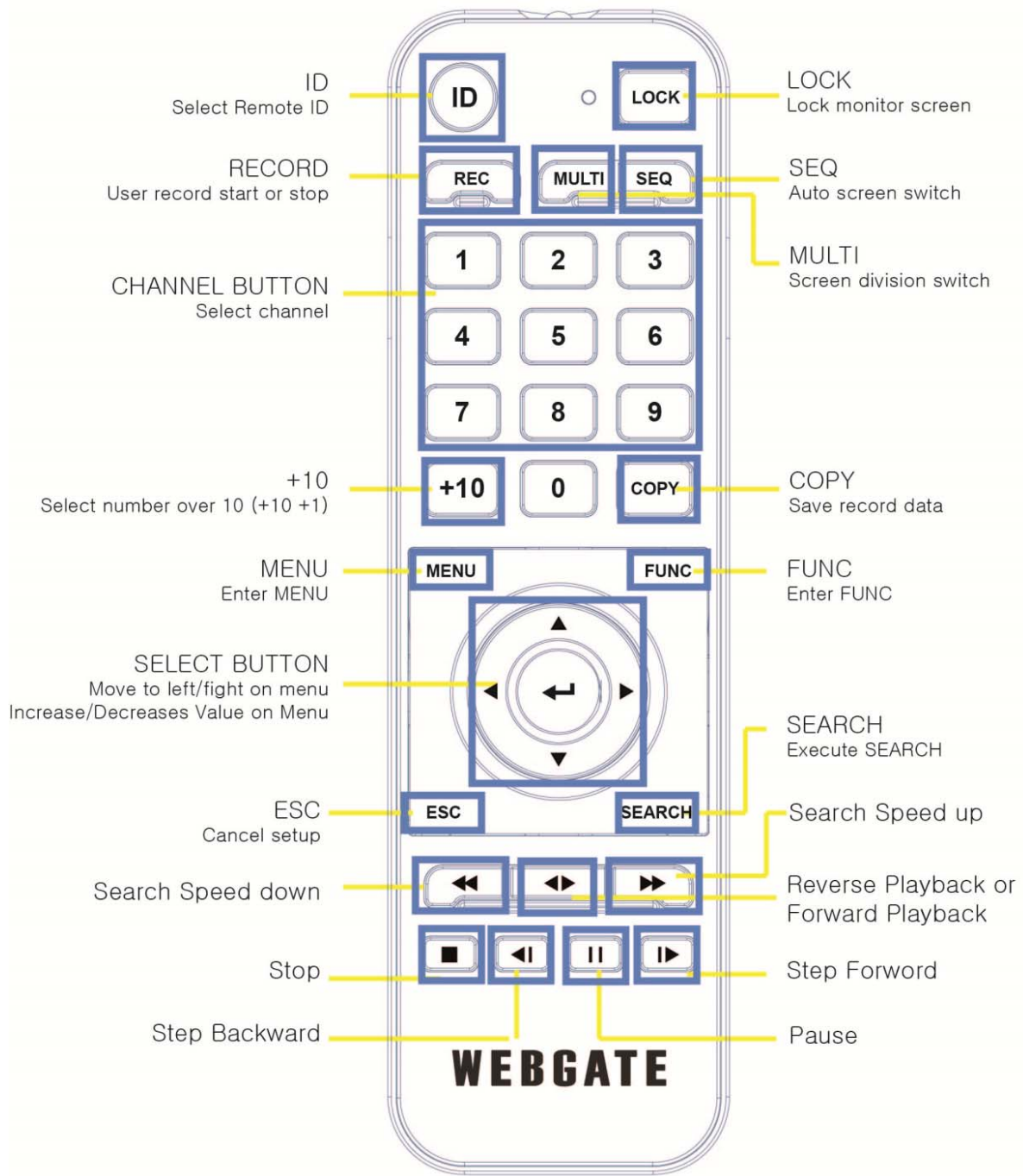

Remote control B

Installation

Check settings

This DVR is high quality security device with a high capacity built-in HDD and important circuits. Before installation, please read carefully below recommendations as high internal temperature of the product can lead to damages and shorten product life cycle.

Recommendations on installing a DVR in a rack.

1. Don't seal the inside of rack where DVR is installed.
2. Keep airflow through inlet and outlet.
3. If there is another device installed in the rack, secure additional space or install air ventilation.
4. Installation of an air circulation fan around each inlet and outlet is strongly recommended.
(Install filter around inlet or outlet for harmful substances)
5. Keep ambient temperature between 5°C~45°C around DVR.

Warnings if HDD is installed

1. Please be extra careful not to damage HDD as it easily breaks.
2. During installation, make sure insulated coat doesn't come off or isn't placed in the wrong place.
3. Don't lose screws and parts.
(If screws or parts are not screwed or assembled correctly, product may not operate)
4. Check HDD compatibility list HDD
(Please check with CS team)
5. Partition table must be removed for HDDs used in PC or other DVR models before installation.

HDD installation *

HDC400F-PD / HDC400F

1. Tighten the both side of HDD bracket using screws.

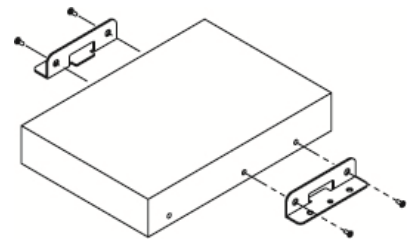

2. Install HDD bracket with HDD into DVR then hold it with screw to fix it to the bottom part of DVR.

<Note>

Socket arrangement of SATA cable in main b'd is as follows.

One HDDs can be installed in DVR.

Main b'd socket	Disk manager
INT E	INT E
eSATA	eSATA

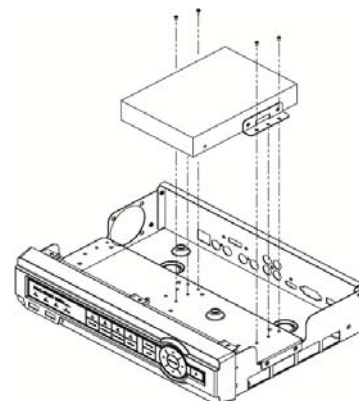

* Varies between different models

HDC1601M / HDC801F-PD / HDC801H

1. Tighten the both side of HDD bracket using screws.

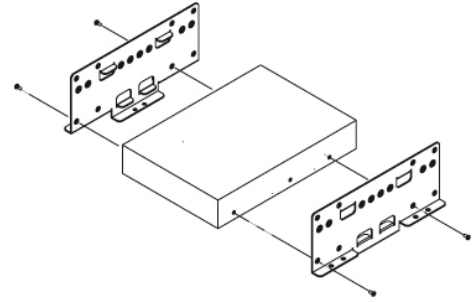

2. Install HDD bracket with HDD into DVR then hold it with screw to fix it to the bottom part of DVR.

<Note>

Socket arrangement of SATA cable in main b'd is as follows.
Two HDDs can be installed in DVR.

Main b'd socket	Disk manager
INT A	INT A
INT B	INT B
eSATA	eSATA

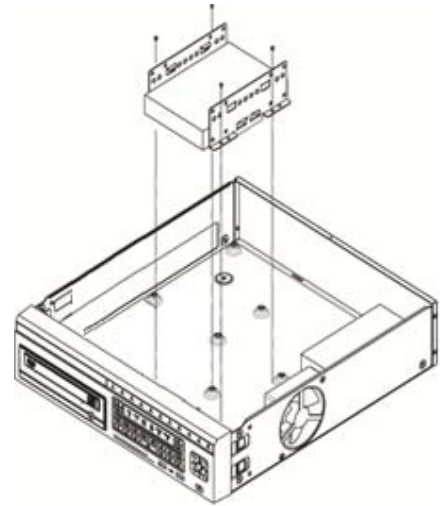

HD1600F-PDR / HD1600F-R

1. Unscrew bracket screws that are fixing it to a DVR..

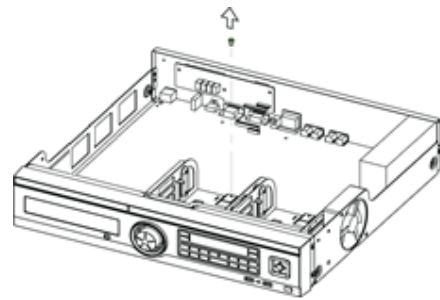

2. Push HDD bracket to a direction shown in the right picture and separate from fixtures.

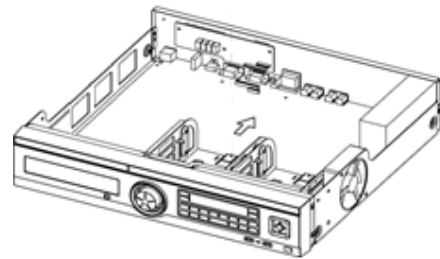

3. Lift HDD bracket to a direction shown in the right picture and separate from the bottom.

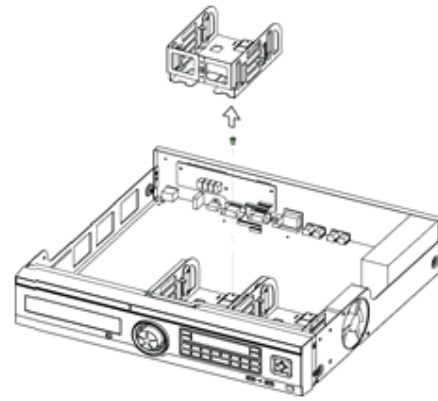

4. Place HDD in a HDD bracket and fasten 4 screws on each side.

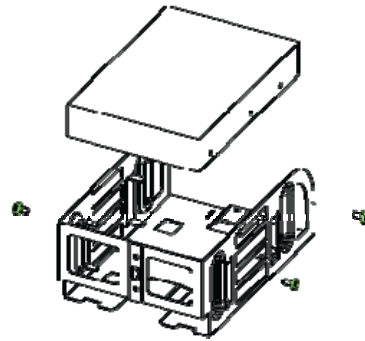

5. Place HDD bracket fastened with screws in DVR and fasten it on the bottom with screws.

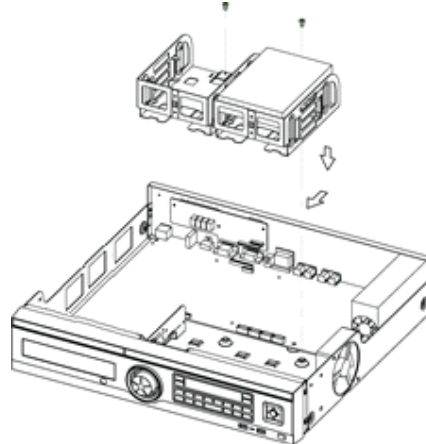

<Note>

Below is SATA cable socket sequence of a mainboard.

Up to 5 HDDs can be installed inside DVR.

Main Board	Disk Manager
INT A	INT A
INT B	INT B
INT C	INT C
INT D	INT D
INT E	INT E
eSATA	eSATA

Adding HDD

Remove the power cord before installation to protect DVR against possible damage and an electric shock. Please call the store you purchased the product from if it isn't operating correctly due to installation or configuration mistakes.

✓ **Warnings regarding Data loss**

Please handle with care so HDD data isn't damaged.

Check HDD compatibility before installing additional HDD.

Be careful not to give any shock on HDD during operation which could lead to possible damage or malfunction.

✓ **Cases when HDD and its data can be damaged.**

To minimize the data loss, please copy data as often as you can.

Physical shock during disassembly or installation may lead to Data damage.

Sudden power outage or turn off of DVR can damage HDD.

Please don't try to move or shock DVR while HDD is working.

Connecting other devices

Basic connections

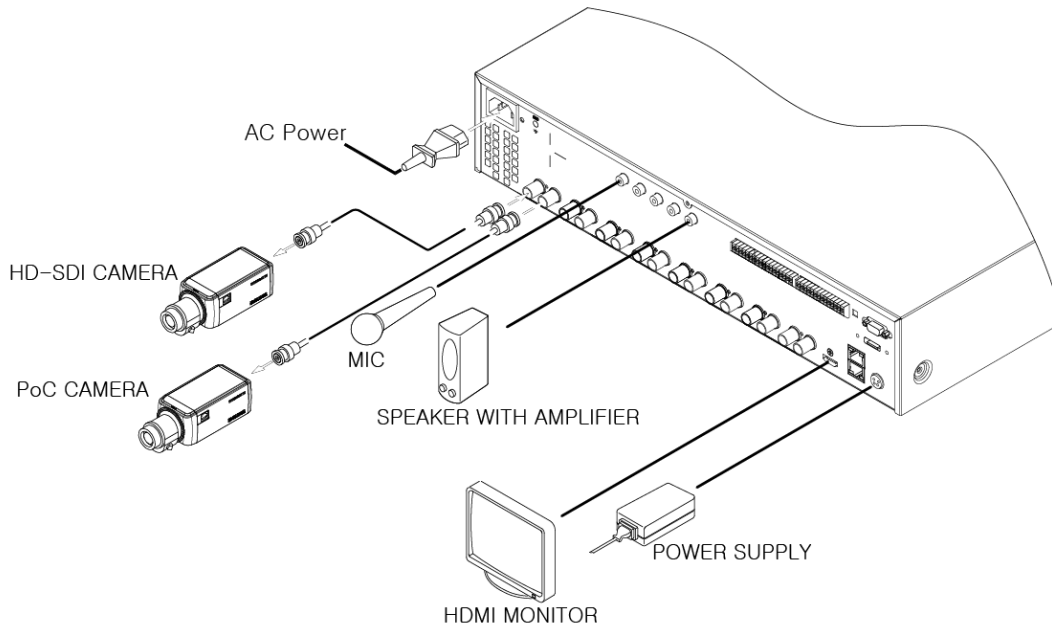

Connecting a monitor

Check monitor resolution and connect to DVR.

- ✓ HDMI Port : 1920 x 1080p

<Note>

Only connect cameras that support HD-SDI standard.

We strongly recommend using HDMI certified cable when connecting to DVR.

Connecting a Camera

Use recommended coaxial cable to connect HD-SDI camera to DVR as shown in the picture.

Only cameras with 1080p resolution can be used. Other resolutions are not supported and channels with resolutions Webgate camera doesn't support will not be recorded.

PoC camera

Connect PoC camera & PoC adapter to DVR to supply power to PoC camera through coaxial cable and no additional power supplies are required. And PoC camera can be controlled using the DVR CoC function through coaxial cable without additional RS-485 cable.

Recommended cable *

Cable Type	HD-SDI transmission distance	Use
5C2V	about 90M	Analog signal
4C-FB(T), 4C-HFB(T), RG59	about 140M	High-foamed cable, double or triple shielded cables are recommended
5C-FB(T), 5C-HFB, L-6CHD, RG6	about 180M	HD-SDI cable
5C-HFBT	about 200M	HD-SDI cable

* Depends on manufacturer and models.

<warnings>

- ✓ Transmission distance will be affected by cable types and installation site environment

- ✓ Transmission distance of the chosen cable will be various based on reduction rate of 750MHz (reduction rate of dB/100m < 25dB is recommended)
- ✓ Foamed or high-foamed trishield cable is recommended.
- ✓ Impedance 75Ω must be used for coax cable connection and connector work.
- ✓ Beware of deformation of cable due to high pressure over the cable.
- ✓ Don't pull the cable with too much force.
- ✓ For DVR input/output, cables will be tied at the rear of the rack. If tied too tightly, inside/outside insulator can be deformed so tie it loosely within cable's curvature range.

Connecting a power cord

When power cord is connected, DVR starts booting automatically.

How to turn off DVR while it is operating : press power switch for 5 seconds, and a pop-up window will appear, then select "YES" to turn off the power. For turn back on the power again, push the Power button.

Connecting an audio

Please see the below picture and use RCA cable to connect audio input/output devices to DVR

Connecting external device

Connecting USB Device

USB port can be used for copy of recorded data and for mouse.

See below table for USB Device specifications.

USB specifications	Ver 2.0 or later
Usable device	USB Stick
Voltage specifications	DC 5V / Max. 200mA

<Note>

USB stick needs to be FAT32 formatted.

DVR may not recognize USB Flash memories that require additional program on MS Windows.

Connecting eSATA Device

If external eSATA storage is used, it can be connected to a rear eSATA port. Additional power for eSATA device will be required as DVR doesn't supply power.

<Note>

1. Check compatibility of eSATA with DVR as not all eSATA are compatible with DVR.
2. If eSATA is connected to DVR when it is on, it may not be recognized depending on external devices. So we recommend following the below steps.
 - 1) Turn off DVR.
 - 2) Turn off eSATA then connect it to DVR.
 - 3) Turn on eSATA.
 - 4) Turn on DVR.

Connecting NS0104R

Connecting to DVR

- (1) Use Gigabit Ethernet Cable and connect to DVR as shown in the below picture.
- (2) NS0104R's DVR Port and DVR's Storage Port must be connected directly.

<Note>

- 1) Use Gigabit Ethernet Cable(Category-6) for Network cables to connect to DVR. Other cables are not compatible with Webgate DVR.
- 2) NS0104R and DVR must be connected by cables and normal operation isn't guaranteed if Hub is used.

Set ID configuration

Use Rotary Switch on the back of NS0104R to set up ID. Different IDs will be needed if 2 or more NS0104R are connected.

Rotate with flathead driver to give ID a value(number)
As shown in the right picture, 100x represents 3 digits, 10x, 2 digits, and 1x, single digit.
ID values must be between 2~254.

EX) if ID is given 100x=1 , 10x=2 , 1x=3 NS0104R, then ID will be given a value of 123.

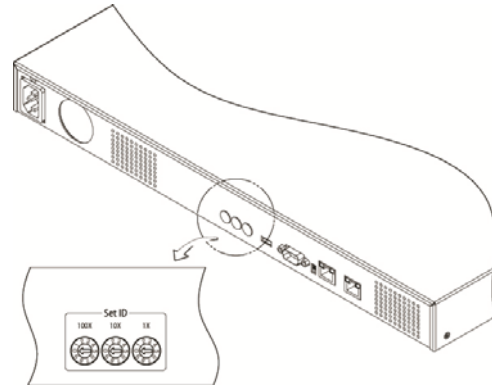

<Note>

- 1) It approximately takes a minute to turn on the power and to connect NS0104R to DVR. While it is connecting, 4 LEDs on the front will be turned on in order and all 4 LEDs may be turned on or off when it is connected to DVR. HDD list can be checked on the disk manager.

Connecting input/out terminals

Wire end handling

See below for wire end handling used in terminal block. Please work on single line and multiple line as they have different thicknesses.

- Multiple lines : Peel off the recommended length(8~10mm) and lead-coat it. Use AWG 22 ~ 26.
- Single line : Peel off the recommended length(8~10mm) and use AWG 20 ~ 26.

Wire insertion/removal

As shown in the picture, push the lever to insert or remove a wire.

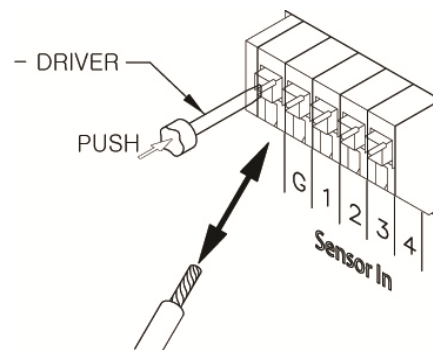

Connecting the sensor specification

below requirements need to be met in order to connect the sensor

Specifications	Input Channel #	16EA Transistor input
	Input Type	N.C, N.O support
	Supported sensor	Dry contact sensor
	Connection method	Connect the trimmed wire to terminal block
Performance	Available input	Minimum 500ms

pulse range	
Output current	Standard DC 12mA

Connecting sensor input terminal

Please see the picture for sensor input. The below picture is an example of connecting Dry Contact sensor type. Please refer to "Wire Handling" for more information.

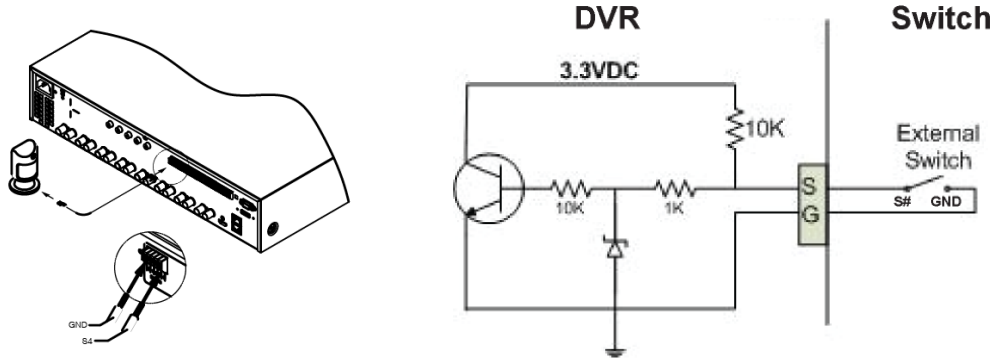

Connecting relay specifications

Please see the below table for alarm output requirements.

Specifications	Output Ch.	4ch relay output
	Output type	Dry Contact
	Connection method	Connect the trimmed wire to terminal block
Performance	DC	30V / 1A
	AC	125V / 0.5A

Connecting relay

Please refer to the below picture in regards to connecting R1~R4 output. Below picture is an example of connecting a light bar. Please see "wire end handling" in regards to connecting/removing wires.

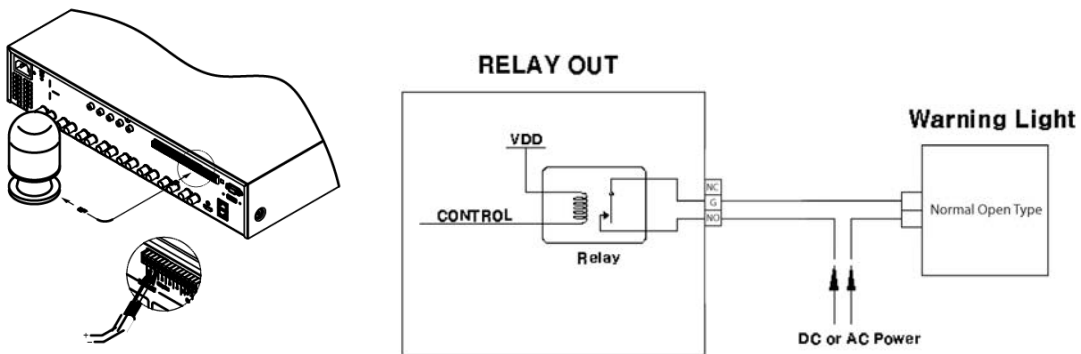

Connecting COM1 serial port with external devices

Connecting Text input device (ATM / POS / Access Control)

Using COM1/RS232, TEXT DATA can be recorded with synchronizing POS/ATM.

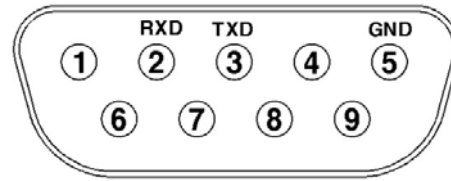
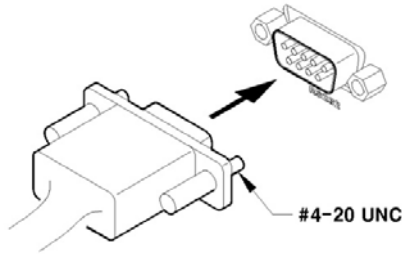

As shown in the picture, for a set up to connect COM1/RS232 (D-Sub 9pin), set up serial & text info under "device" menu.

Connecting COM2/COM3 serial port external device

Connecting serial communication terminal for PTZ device & Keyboard device

Control PTZ devices and Keyboard devices by connecting them to DVR's COM ports. Picture in the right shows how a camera and a keyboard device with PTZ function are connected to RS-232 COM1 & RS-485 COM2 respectively. Other serial communication terminals will be connected to other devices as shown in the below picture.

To connect or remove a wire, please refer to the "wire end handling" and supported models can be checked on "compatible PTZ & Keyboard device" on the supplement booklet.

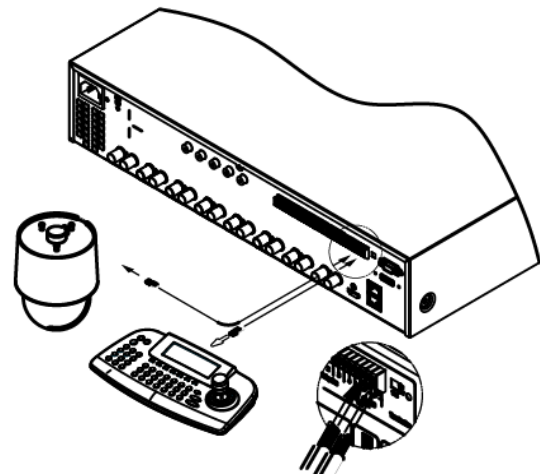

Connecting Serial Port for Transparent device

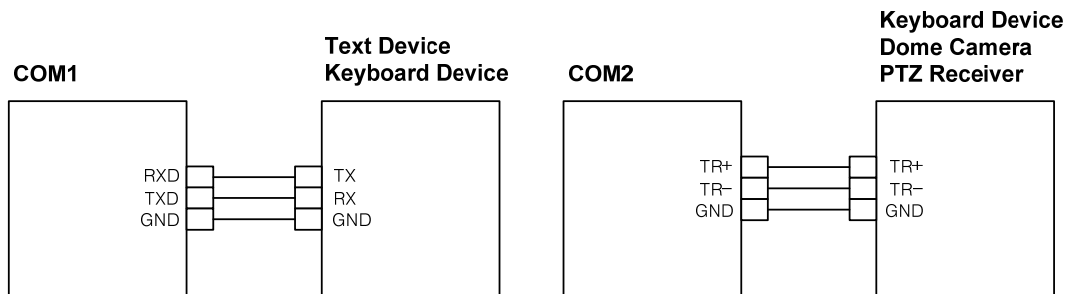

Connecting PTZ & Keyboard

up to 255 DVRs can be connected using keyboard and PTZ control is possible for all channels connected to DVR. Also, multiple keyboards extension as Slave can be used limitless with Master Keyboard. In this case, Master Keyboard has priority for all controls. Please refer the instruction manual for PTZ keyboard connection & its way of control which comes with PTZ/ Keyboard.

Configuration using 2 serial ports

PTZ(DOME) and Keyboard can be connected to DVR's 2 serial ports. In such case, keyboard can control DVR and PTZ(DOME) at the same time, and DVR can control PTZ(DOME).

The below diagram represents configuration of multi DVRs with PTZ(DOME). To control PTZ(DOME) using keyboard, please select DVR ID then select camera for control.

control device	connection device
Keyboard (Master/Slave)	All DVRs can be controlled, all PTZ(DOME) can be controlled
DVR	PTZ(DOME) directly connected to DVR can be controlled

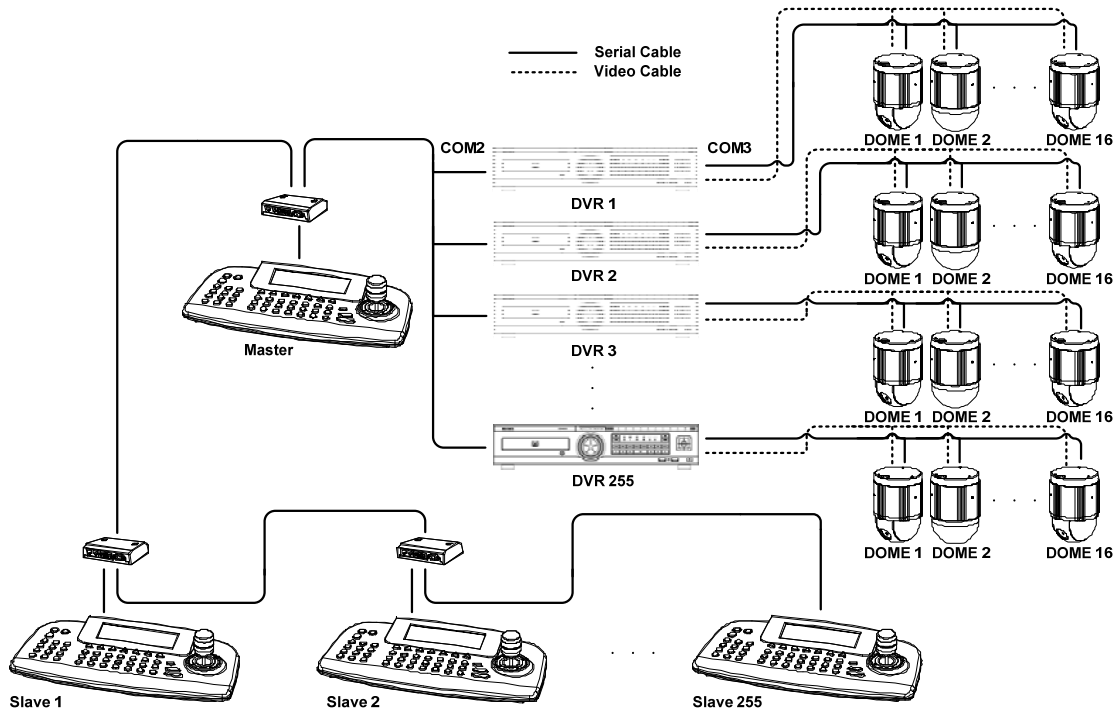

Confituration using 1 serial ports

When using 1 serial port, user can connect both of PTZ(DOME) and Keyboard to a port, and user can select a PTZ(DOME) through the keyboard. According to DVR's COM port setting, connected controllable device can be selected, and by choosing a DVR ID, keyboard can control several DVRs.

In case PTZ(DOME) is setup on DVR COM port, user can use it as follows.

Control device	Connection device
Keyboard (Master/Slave)	All DVRs can't be controlled/ All PTZ(DOME) can be controlled
DVR	Only PTZ(DOME) directly connected to DVR can be controlled

In case Keyboard is setup on DVR COM port user can use it as follows

Control device	Connection device
Keyboard (Master/Slave)	All DVRs can be controlled, All PTZ(DOME) can be controlled
DVR	All PTZ(DOME) can't be controlled

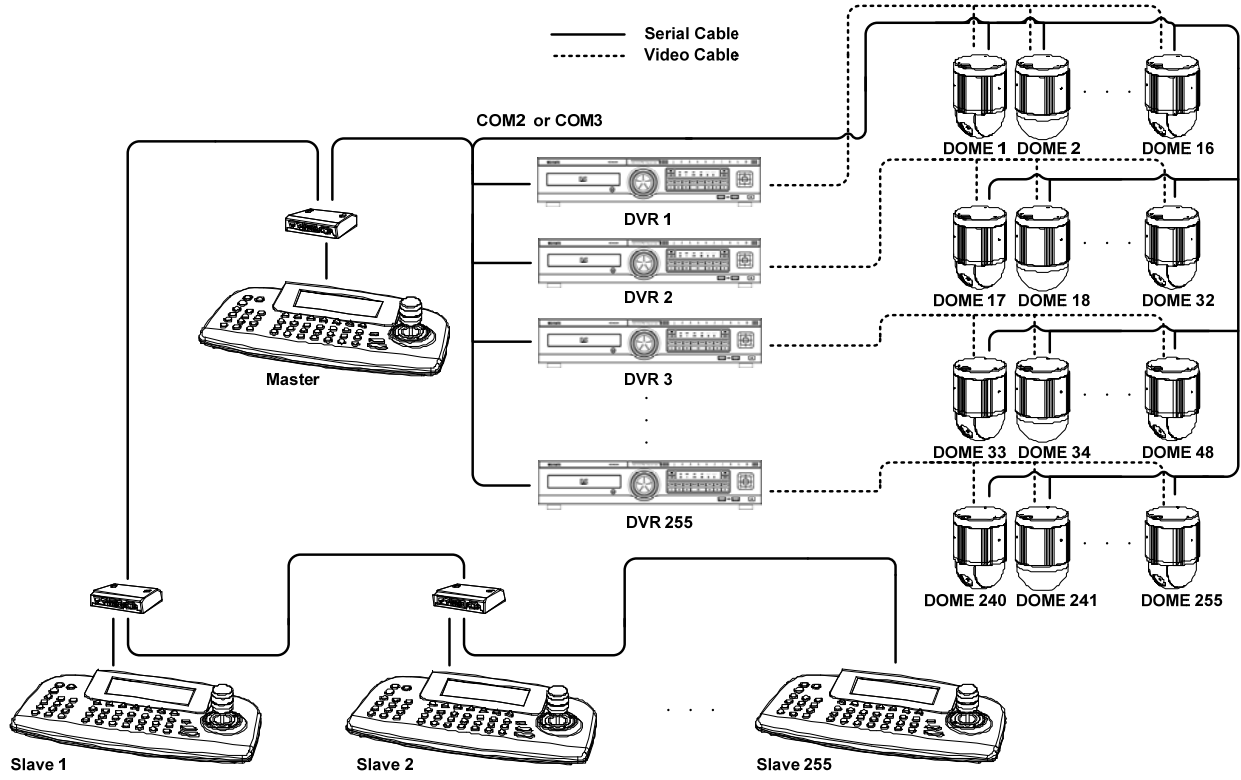

Usage

Menu Structure

Press [MENU] key on front panel or click [Main Menu] button under FUNC menu to enter the setup menu. To exit menu, press "X".

Main menu

The selected tab is shown in bright color and the sub-menu box will show the chosen To move to the previous/next tab, use the [◀/▶] arrow buttons. To move to a chosen sub-menu press the [Enter] key or click on the menu you want to view if you're using a mouse.

Sub-me

Selected sub-menu will display the chosen item and the related setting will be shown. To move to the previous/next tab, use the [◀/▶▲/▼] arrow buttons. To move to the related setting press [Enter] or click the mouse. To move to the upper main menu, click the [Save Changes] at the bottom of menu, or press [ESC] button.

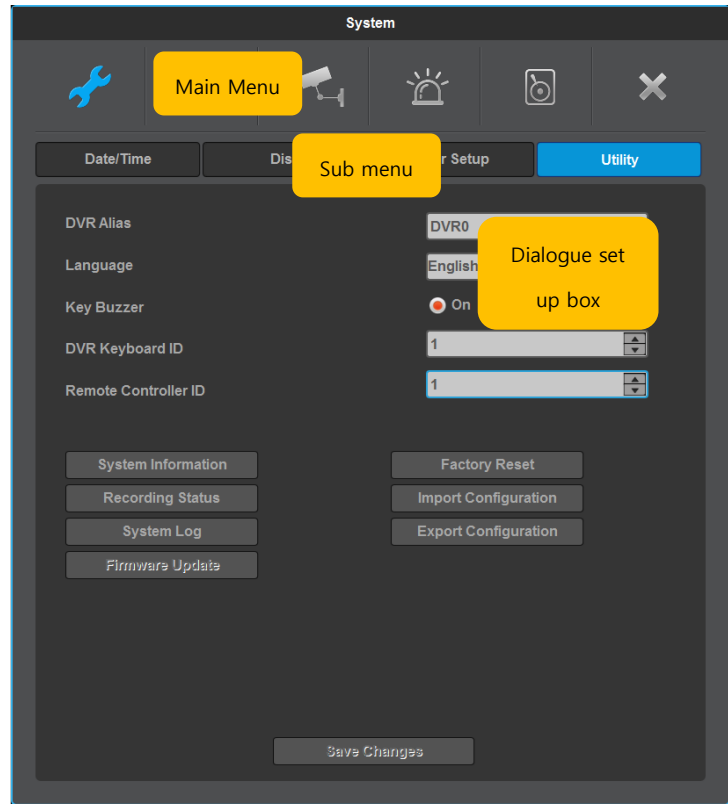

Set-up dialogue box

The selected tab is shown as orange, and To move to the previous/next tab, use the [◀/▶] or or click the mouse. To modify the configuration values, click the mouse or use the [◀/▶]

Dialogue box for string input

Dialogue box for string input is shown as follows. User can enter words or numbers using a mouse or direction buttons.

Use [▲/▼], [◀/▶] to move to select a letter and press [Enter] or click a mouse to enter it. To delete the entered letter, press [←] button, and to enter a space, press [SPACE] button. To exit the dialogue, press [ENTER] button to save string and exit or press [CANCEL] button to cancel the string.

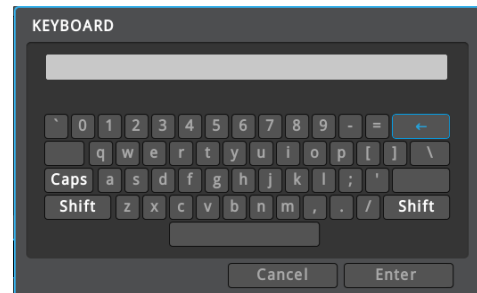

Default setting

Check video

When turned on, DVR starts booting automatically and shows screen after the booting.

<reference>

If user password is set, a box will appear to enter the password, and only numbers(channel) can be entered in the box.(It is not a default setting by factory)



Date & Time settings

Menu → system → date/time

Standard time zone

Use the left or right arrow key on the front or the mouse wheel to select your time zone. (To go to the previous menu, press the [ESC] button on the front or click "X" with a mouse. This is the same for all OSD menus.)

Daylight Saving Time (DST)

On the "time zone" setting, "on" will be chosen when users click on regions where daylight saving time applies and "off" will be chosen when regions without daylight saving time are chosen.

Users can check "off" if they don't need daylight saving time function for region where daylight saving time applies.

Please select "custom" if users want to set their own daylight saving time preferences. Select "custom" and DST setting will appear. "month/day" will set DST start/end at month/day/hour and "month/week/day" will set DST start/end at month/week/day/hour.

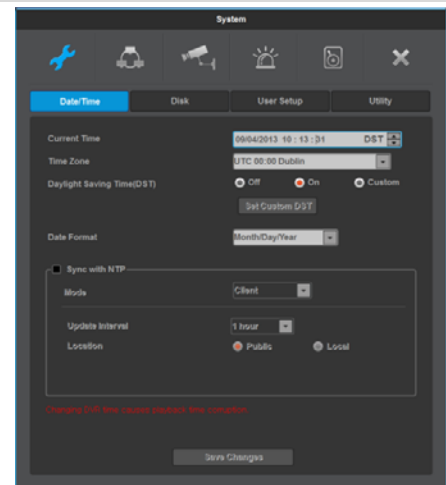

NTP function

Please set NTP 'On' then select 'Public' in Client Mode for DVR to set time automatically via internet connection

Date Notation

Please select "Date Format" and select one of 'YYYY/MM/DD, MM/DD/YYYY or DD/MM/YYYY

Recording configuration

menu → recording → recording

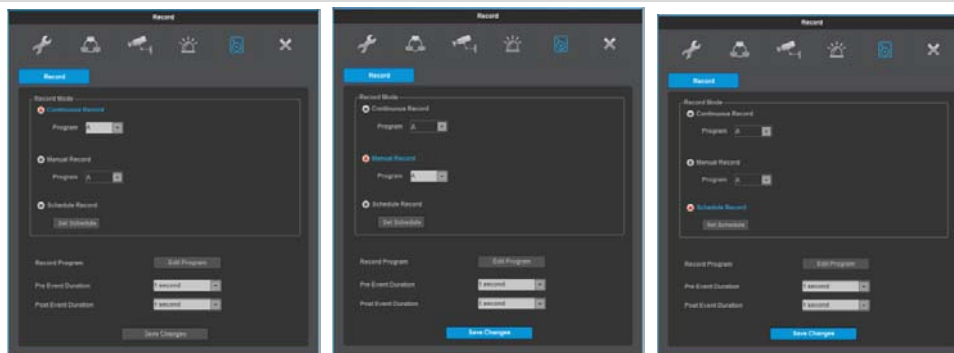

[continuous recording]

[manual recording]

[schedule recording]

Continuous recording

Continuous recording will automatically begin after the booting is completed and continuous/event recording will begin according to the chosen program values.

Manual recording

Push REC button on the front to begin/end manual recording and manual/event recording will begin according to the chosen program values.

<reference>

If manual recording is chosen, exit menu and check the manual record indicator on the status bar to confirm recording. If there is no manual recording indicator sign, press REC button on the front to begin recording.

schedule recording

Schedule recording will begin according to a pre-set day/time schedule.

Set day/time on " schedule setting" under the schedule recording mode.



Program configuration

Menu → recording → program

Please set resolution, frame rate, and picture quality of each individual camera per channel in "Program menu" under the record setup.

<Reference>

How to check if it's recording : If set correctly and is recording, "REC LED" indicator on the front will be flickering. Also, status bar's save indicator will show [SCHEDULE], [MANUAL], or [continuous] indicating that all channels are recording. "REC LED" is turned off when it isn't recording.

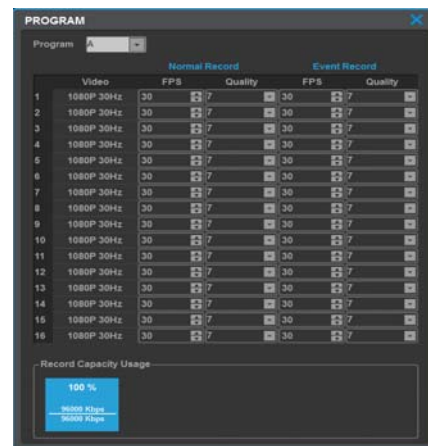

Use of Input/Output device

Setting sensors

menu → event → sensor

Please set each and every sensor. Select a sensor, and select a type and click [save] to complete the setting.

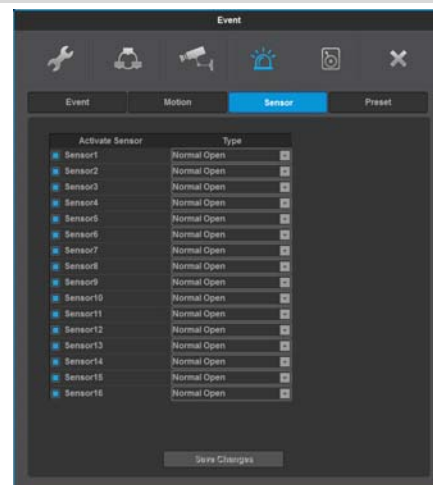

Relay setting

menu → event → event

Select from normal event group, "sensor, motion detect, text, Video Loss" or system event source group, "Disk error, Disk full, Fan error, authentication fail, WRS registration fail, Mirroring fail, abnormal Recording stop" to run relay. Also, user can set working condition by schedule. In case of using control center thru. Network, relay could be run from remotely

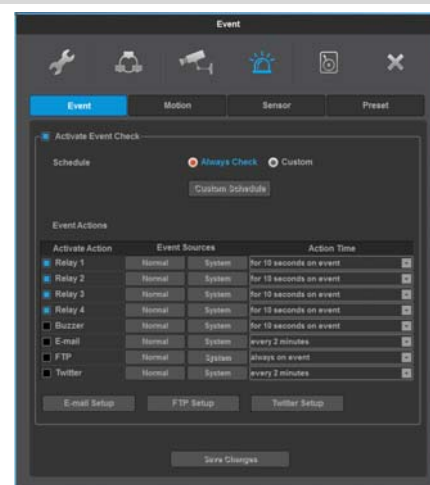

Copy

copy

Press [COPY] button on Function menu to run COPY menu. When back up device is connected correctly, disk is recognized automatically as following image and it is processed in order selecting copy type → Setting copy section → Selecting drive → Copy execution

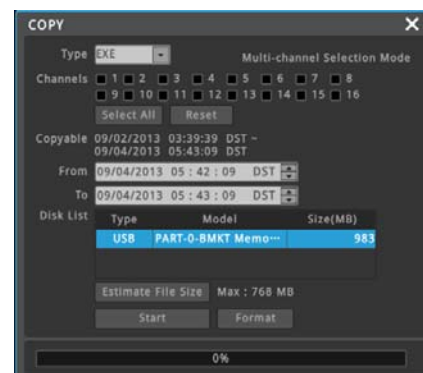

PTZ

Menu → device → PTZ

At PTZ menu, PTZ's serial port per each channel, Protocol, PTZ address and Baudrate can be configured. Additionally, PTZ home function, Idle time, Parity bit, Stop bit can be configured.



HDD registration and format

menu → system → disk

After mounting HDD and booting, "Disk Manager" will run automatically as shown in the right picture.

If it doesn't run, please check the connectivity of HDD

- (1) Select a HDD among listed HDDs. Activate the HDD and execute format.
- (2) Check "YES" for the formatted HDD..

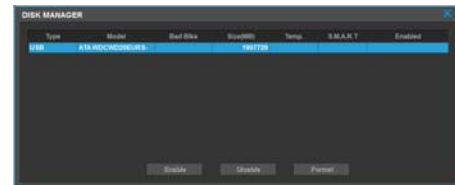

<warning>

Please call Webgate or Webgate dealers for HDD compatibility

HDD replacement

- (1) turn off the DVR, take out a HDD and install a new HDD.
- (2) turn on the DVR again, open "Disk Manager". Select the removed HDD, and press [Confirm] to remove the HDD from the list.
- (3) Select the newly installed HDD and format it after completing the activation.
- (4) check the enabled box "YES" for the formatted HDD.

<Note>

HDD re-use

You can use HDD that has been used before from DVR, without deleting its data.

Install the previous HDD in the DVR, select from the list and activate it. Enabled box will be checked "yes".

Remote monitoring and control

Via Internet/Intranet, user can use PC to control from the remote site. Enjoy the same control over DVR through PC as you'd have on the spot from the remote site.

Ethernet Connection

Turn off DVR, connect Ethernet cable to DVR and turn it back on.

<reference>

To protect DVR from damage, after connecting Ethernet cable, input Power.

Plug in ethernet cable tightly. Input power on DVR and check its connectivity.

Network configuration

menu → network → network

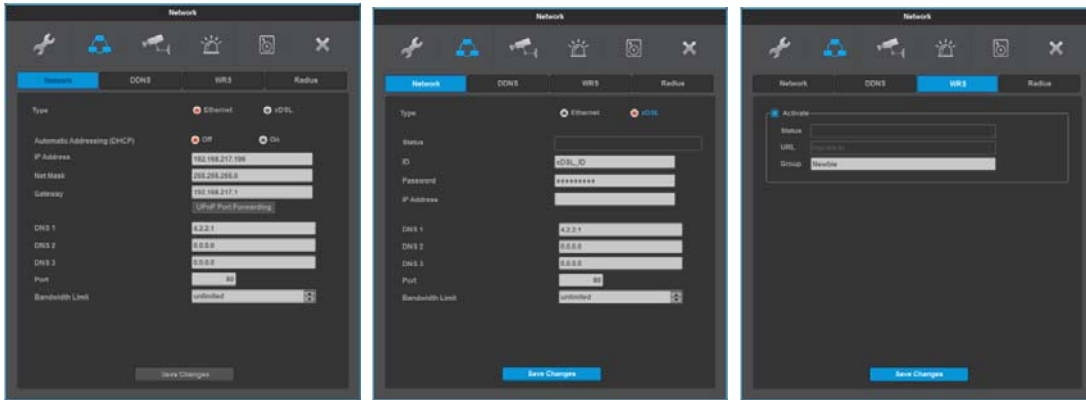

Ethernet

Click Ethernet for type and enter given IP, Netmask, Gateway, DNS.

xDSL (PPPoE)

Change Network menu type to xDSL then go to xDSL menu.

Enter ID and Password assigned from PPPoE registration on xDSL menu.

Connection confirmation message will appear when xDSL connection is secured.

DDNS

If DVR is using dynamic IP, use DDNS function to get domain name to access to network regardless of IP change. Enter domain name on DDNS menu. For more information, please go to WNS(www.mycam.to), Webgate's DDNS service website.

WRS

If DVR is using dynamic IP, use WRS service to automatically find the product IP to access. Configure GROUP ID to activate WRS function. Use GROUP ID or SN to Search product in CMS and it is recommended to create a unique GROUP ID configuration to avoid GROUP ID duplication.

Remote control ID configuration

menu → system → tool

When operating more than 1 DVR, it is possible to manage many DVR with one remote control by giving different ID to each and every DVR. A remote control can have maximum of 255 IDs and if users want to use every ID, then select ALL.

Select and control DVRs that have different ID with one remote control.

Selecting remote control ID

- 1) Point a remote control at DVR and press ID on the remote control.
- 2) Press ID on the remote control shown on the screen of DVR.
- 3) Press again ID on the remote control to complete the selection.

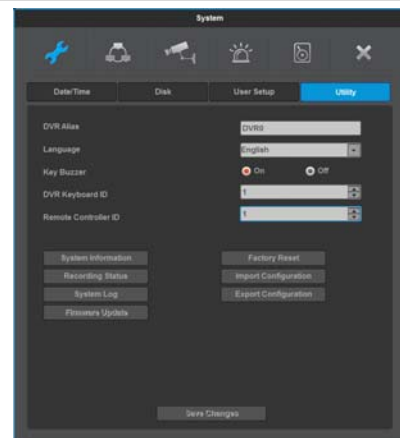

Menu usage

Menu structure

Refer to the below picture for The menu structure and read the explanation in each box per item for a set-up guide.

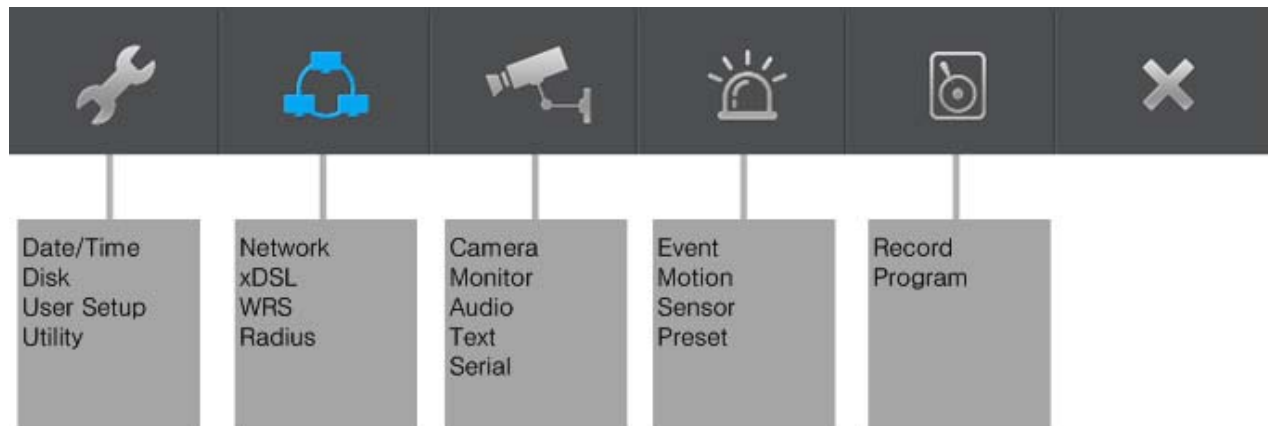

FUNC menu

To run Function menu, please, click the right button of mouse in live monitoring or playback status or push "Func" button on the front panel.

The Function menu enables every function of the product to be controlled by a mouse.

Each function can be executed by clicking left button of mouse.

The Function menu also can be controlled by front part of DVR's buttons.

Please refer to the picture to right for the Function menu structure..

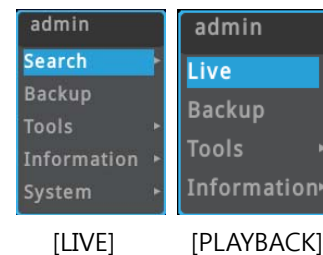

Monitoring

Login screen

DVR will turn on automatically once user connects power to DVR.

All LEDs are turn on and off in order when DVR boots up.

The basic screen will be black with login window pops up.

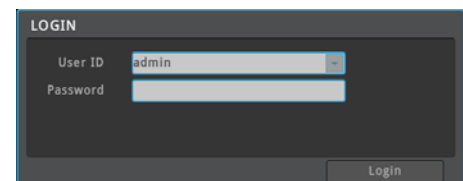

Basic screen

The basic screen will be maximum multi screen DVR supports and if rebooted after multi-screen mode has been modified, previous multi-screen mode will be shown.

single screen

click the channel number you want to view or click the left mouse button.

Click [MULTI] button or click the left mouse button again to return to multi-screen

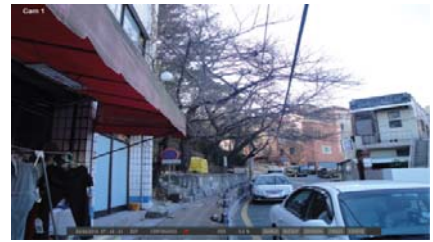

Multi screen

Click [MULTI] for multi-screen display or press multi under func menu to choose multi-screen mode.



Screen description

The status bar from monitoring screen shows DVR's current status which includes the following: Date/Time, Record status, Motion Detection, sensor input status, text input, Manual Record.



auto switch mode(Sequence)

Auto switch screen mode is a feature in which the selected channel or multi screen division switches in sequence with the time interval of 1 – 60 seconds.

(Please refer to "Monitor setup" for further configuration method).

Auto Switch mode can be set in every division mode by pressing the [SEQ] button.

Press [SEQ] button once more to leave from Auto Switch mode..

event screen

It is available to set the selected screen pop-up automatically when an event is triggered

Users can choose events for pop-up from event source. Event source supports 3 types of events: Sensor, Motion Detection & Text.

If multiple events are triggered, the corresponding screens will pop up automatically.

For example, if events are triggered in 3 Channels, they will be displayed in 4 screen division automatically. To return to the original channel, press the button of one of the popped up channels.

Press [ESC] to return to original channel.

<warning>

If Alarm pop-up is "Off", Event pop-up will not be enabled.

If event screen switch is set "Keep", it keeps showing pop-up image until users press a button. To return to the previous screen, please press any button.

Enlarged screen

Using D-Zoom on a single screen, users can enlarge the section they want to view..

Press [zoom] on a single screen in a full screen mode or press D-Zoom while pressing [func] to enable D-Zoom mode.

Use "+,-" or drag a mouse to enlarge/reduce the screen.

The initial location of the enlarged screen is the center. Use the direction keys to move the enlarged image 22 steps to left/right and 14 steps up/down.

Enlarge mode can be used between 1.00X ~ 10.00X range.

"🔄" To return to the previous screen, select a button and press the enter or left click the mouse..

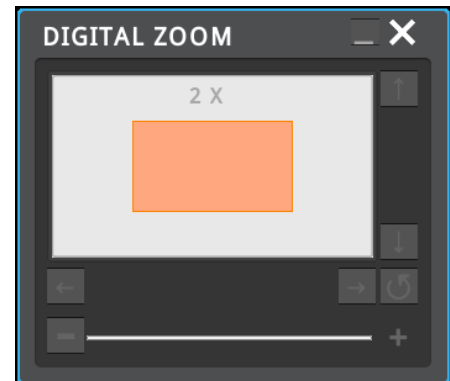

Pausing the live screen

Just like in playback, Live screen can be paused.

click PAUSE button, live display will be paused, and it returns to live display again after pressing any button

PTZ control

Connect PTZ camera to DVR and set relevant protocol on "PTZ" under MENU, and users can operate PTZ while monitoring live images.

Instant PTZ

PTZ mode will automatically be on if Instant PTZ switches a set channel to a single screen. + sign will appear in the middle of the screen if PTZ is operating.

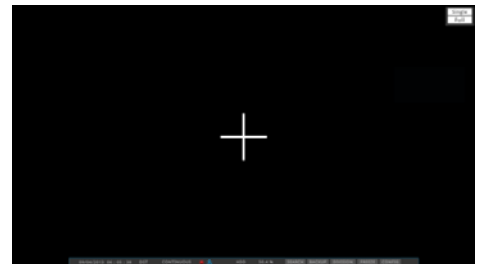

PTZ

When PTZ is on, through PTZ button on front or PTZ buttons under FUNC menu, users can use pan/tilt, zoom, focus, aux and preset functions.

Focus

Click "near", "far" buttons to focus.

zoom

click "In", "Out" buttons to create a preferred focal point.

pan/tilt

pan/tilt function for PTZ configuration channel

Use "Up", "Down", "Left", "Right" to control pan/tilt.

Loading preset

Used to move to set preset location.

Select wanted Preset number and press [Load] button.

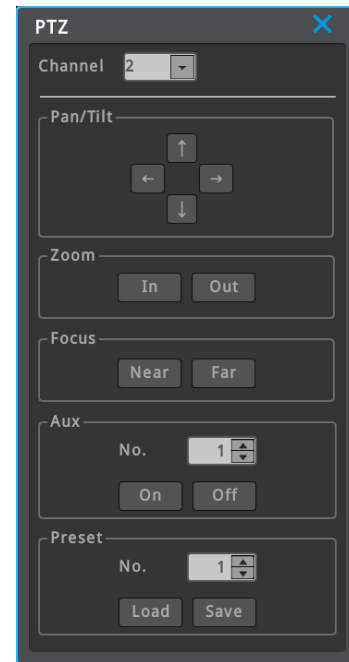

Saving preset

Use to save new preset location.

Use focus/zoom/pan/tilt to move to a location you want to save it and select a preset number and press [save] button.

Auxiliary On

Use direction keys or mouse wheel to select aux number.(up to 16 Aux functions can be used). Select "on" and press enter or click a mouse)

Auxiliary Off

Use direction keys or mouse wheel to select aux number Aux

Select "on" and press enter or click a mouse.

Camera Setup

Use to enter the menu of the connected PTZ device.

Use the front "direction keys" and "enter" button to set up a menu.

Press esc or "⏏" to exit conso menu.

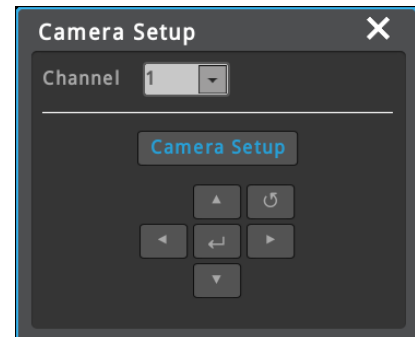

Search and playback

Playback

Playback with Basic Screen

- ✓ In monitoring mode, Press [◀/▶] button to playback the recorded video in full screen
- ✓ If [PLAY] button is pressed, the last playback will run at 1x speed.
- ✓ If [FWD] button is pressed, playback starts from 1min earlier than recent time at 1x speed.
- ✓ If [REW] button is pressed, reverse playback starts from 30 second earlier than recent time at 1x speed.
- ✓ If [PLAY] button is pressed in multi screen mode, playback will start in multi screen mode.

Playback function

button	function	function description
◀▶	playback	Playback 1× speed. When using mouse, click search button under Function menu. If [◀▶] button is pressed in monitor mode, DVR replays from the last replayed position. Pressing [◀▶] button during playback makes reverse replay.
	pause	Pauses the playback
■	stop	Stops the playback.
▶▶	High-speed forward playback	Different playback speed (in the order of x1, x2, x4, x8, x16, x32, x64, x1, x2, x4)
▶	Step forward playback	During playback, Press ▶ while pressing to step forward the playback. To return to normal playback mode, press [◀▶]
◀◀	High-speed reverse playback	Different reverse playback speed (in the order of x1, x2, x4, x8, x16, x32, x64, x1, x2, x4)
◀	Step reverse playback	During playback, press ◀ while pressing to step reverse the playback. To return to normal reverse playback mode, press [▶].
Jog/Shuttle		use outside dial to forward or reverse the playback in x1, x2, x4, x8, x16, x32, x64 speed. Also, use inside dial to step forward or step reverse the playback.





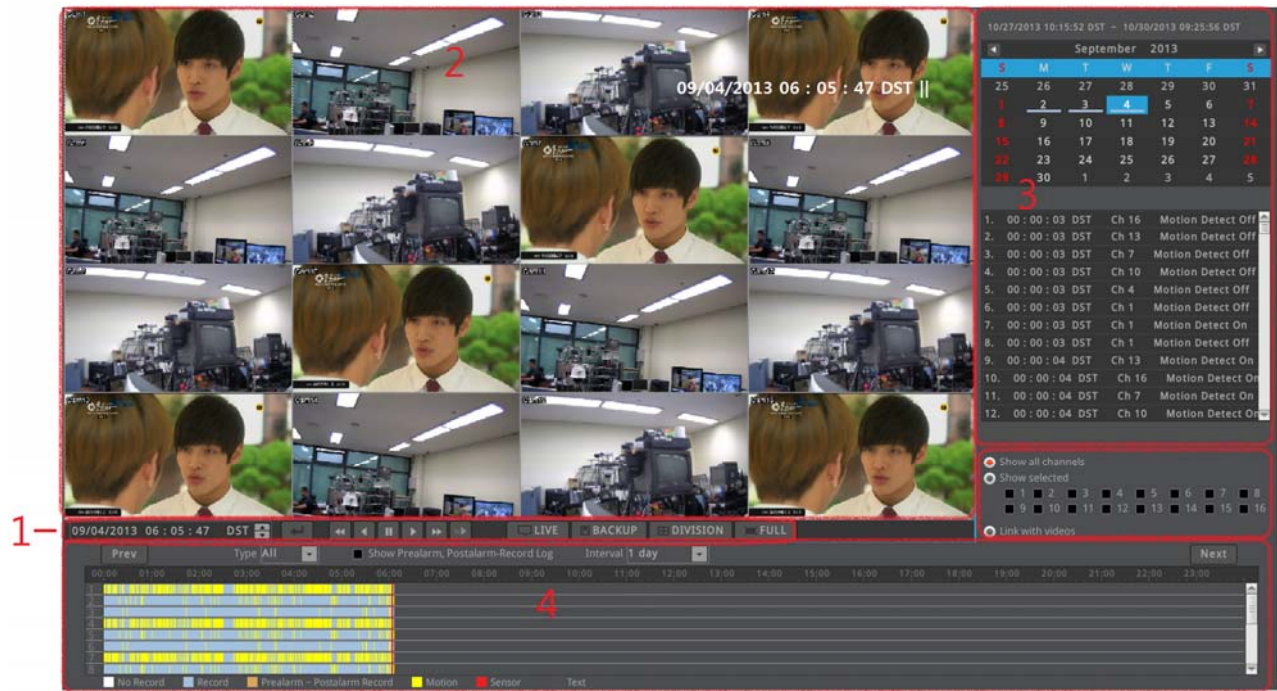

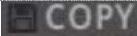

Screen composition/names of the functions

Screen composition



	name	function description
1	Playback button	Use buttons to control the playback.
2	screen	Displays the playback videos.
3	log viewer	Displays the log seen on timeline
	Calendar/time search	Select a date on the calendar to view the data of the date.
4	timeline	Displays the info of the unit and search the playback sections.

Icon function description

buttons	description
	Use to move to live mode.
	Use to COPY
	Used for multi-screen mode.
	Switches to full screen mode
	Reverse playback button
	1x reverse playback button.
	Pauses the playback.
	1x forward playback button.
	Forward playback button.
	1/2 forward playback button

Time search

Enter the date and time you want to search and press enter to move to the entered date and time.

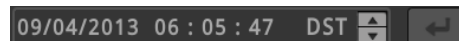

Calendar search

When calendar search is run, it marks the dates on which there were recordings.

Select a date from calendar you want to search, and it moves to that date.

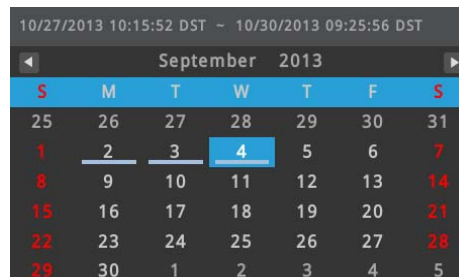

Event search

Event info(All, Motion, Sensor, Text, None) is shown on timeline.

Select a list to move to the selected time.

Time	Ch	Event
00 : 00 : 04	3	Motion Detect Off
00 : 00 : 04	4	Motion Detect Off
00 : 00 : 04	1	Motion Detect Off
00 : 00 : 04	7	Motion Detect Off
00 : 00 : 04	5	Motion Detect Off
00 : 00 : 04	2	Motion Detect Off
00 : 00 : 05	7	Motion Detect On
00 : 00 : 05	1	Motion Detect On
00 : 00 : 05	2	Motion Detect On
00 : 00 : 05	5	Motion Detect On
00 : 00 : 05	3	Motion Detect On

Copy

This is for copying recorded videos. There are 2 types of copying, EXE, and AVI. Only authorized users by security settings can use the Copy function. For more about authority settings, please refer to (user setup) section.

To run copy function, press [COPY] on the product front or Click Copy button under Function menu. If a user runs copy menu during playback, playback time will be set as backup start time.

EXE

Use USB stick to back up and use mini player or control center to playback. It is possible to select a part of channels depending on the choice of the channel list made by a user.

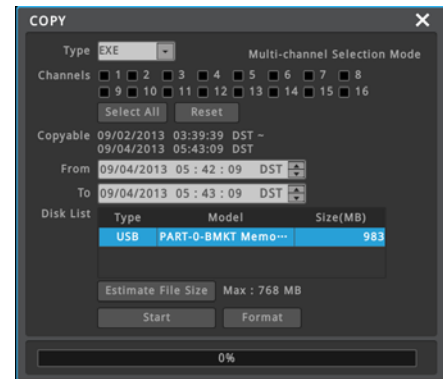

Name	function description
type	Select EXE using direction keys or mouse wheel.
channel	Press enter on a channel or right click a mouse to select a channel. (Select All : select all channels / Reset : cancel the selection of all channels)
format	Format a USB stick before copying. Press Format or right click a mouse to begin. (supports FAT32/NTFS)

<Warning>

If backup isn't 100% complete, then normal playback on PC isn't possible.

AVI

Users can backup via USB memory. The specific part of channel can be copied but it is impossible to copy multi channels at the same time. There is no specific player required but users can playback files using common media player.

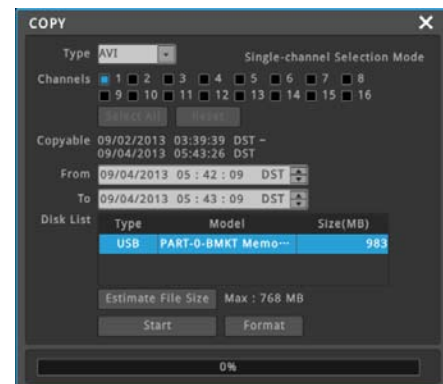

<Caution>

If copied file doesn't play back, please, install integrated codec first.

configuration

system configuration

Please set time/disk/authority.

date/time

menu → system → **date/time**

Set the product time in order to set recording settings.

It is very important for DVR to have the right time zone in which it is used for protection of recorded videos.

Default time zone is set at 'UTC 00:00 Dublin'.

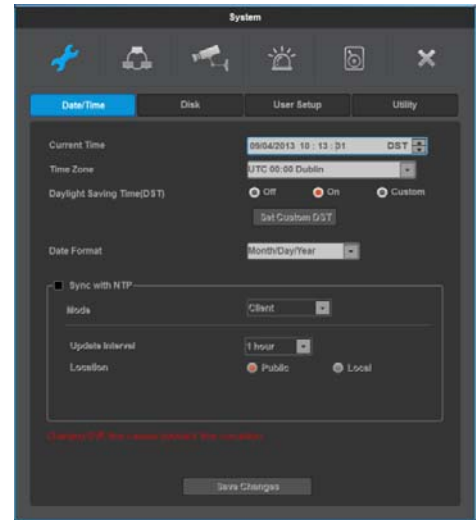

Time settings

<note>

Under recording, if a user changes time when it is already recording(saved in HDD), it will change the time of the previously recorded videos. Moreover, there will be a history of a time change on the system log.

Standard time zone

Set the timezone to the location a product is used in

daylight saving (DST)

This menu is synchronized with time zone configuration menu. It means only when daylight saving area is on, this function works. Daylight saving applicable area is the same as with Microsoft Windows time zone. Users can select whether to apply daylight savings or not when DVR is installed in Daylight saving applied zone

Date format

Date display settings. Select one of "yy/mm/dd", "mm/dd/yy", "dd/mm/yy".

Save changes

To apply the changes made for date/time, click "date/time apply" button.

<warning>

Other configurations except date/time save automatically, but "date/time" configuration doesn't save automatically since it can critically affect HDD recording file system.

To apply the changed value, user must click [date/time apply] button

NTP

menu → system → date/time → **Network Time Protocol(NTP)**

NTP (Network Time Protocol) synchronizes the time of all connected device. To set DVR time to standard time open server which offers standard time on the network and client which is connected to open server to receive time and synchronize it with standard time. Besides that DVR can be set as server to offer standard time to other devices and can be set as both server and client as well.

NTP server location

Enabled when NTP mode is set as client/server. Select if NTP server is public or local.

NTP local server IP

Enabled when NTP server is set as local and sets server IP address. Enter NTP server IP address located in local network or DVR IP address with NTP mode as a server.

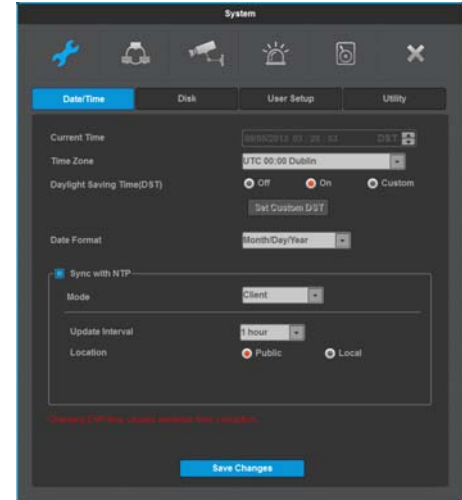

NTP mode

Set DVR NTP mode to client, server or both.

Name	function description
client	Receives standard time from external or internal server and enable Time synchronization of DVR
server	Make DVR a NTP server and provide standard time to other DVR or devices.
both	use both client and server at the same time

Interval

Configure interval of time sync.

Disk

menu → system → disk

Sets up a Raid which add/remove/format internal/external hard disk.

Over Write(Auto Deletion)

If there is no space in HDD, old data will be deleted automatically.

Full Disk Warning

It gives a warning if it is saved to the pre-set limit.

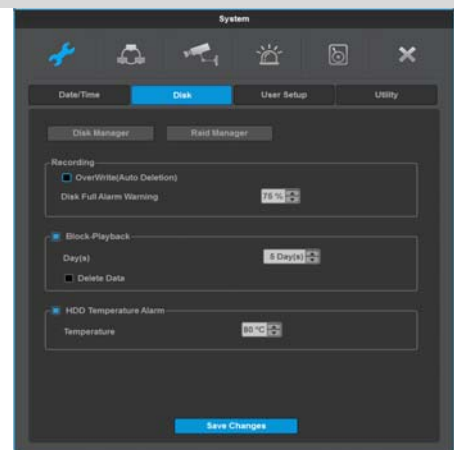

Playback block

This function allows only recordings of pre-assigned date to be viewed.

For example, after 10 days of recording(picture 1), if playback block is set at 2 days(picture 2), then as shown in the picture, only the last 2 days of the recordings can be played back.

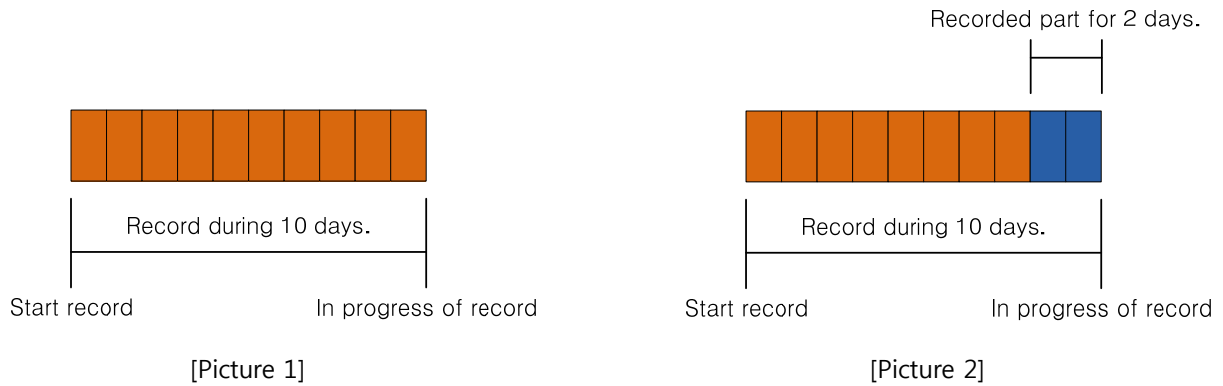

Data deletion

This function allows only recordings of preassigned date to be viewed. For example, if playback block is set at 3 days, then DVR will only save data for 3 days and will delete data more than 3 days old even if auto-deletion isn't on. Once deleted, it can't be restored so please be extra careful.

Disk manager

menu → system → disk → disk manager

This is menu for the management of internal or external HDD. It manages HDD status, bad block, capacity, temperature, and whether to use HDD or not.

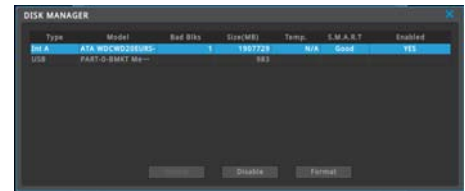

name	Function description
type	Displays the location and types of a disk. Int A (internal A HDD), Int B (internal B HDD), eSATA (external HDD), USB
model	Displays HDD model.
BAD block	Highlights the HDD with BAD block. 0 is shown when there is none. For HDDs not in use, no bad block is displayed.
size	HDD size will be in MB.
S.M.A.R.T	Displays if HDD can be used or not. Good : normal , Bad : abnormal (HDD needs to be replace.)
enable	Displays if HDD is in use or not. Yes : can be used / No : can't be used

HDD YES

- select HDD in HDD NO mode and click [enable] button.
- HDD which has previously been used by DVR will be used without formatting and HDD which has never been used will be formatted and then used.

HDD NO

- select HDD in HDD YES mode and click [disable] button.

FORMAT

- can only run when enabled and click [format] after selecting HDD that needs to be formatted.

RAID manager

menu → system → disk → RAID manager

RAID manager is a menu that manages the RAID of internal HDD. Select disks which you want to manage and decide the RAID Level. If you click the "RAID Creation" button, these disks will create the "DVR Raid Disk".

You have to enable this "DVR Raid Disk" at "Disk Manager" menu in order to use it as recording device.

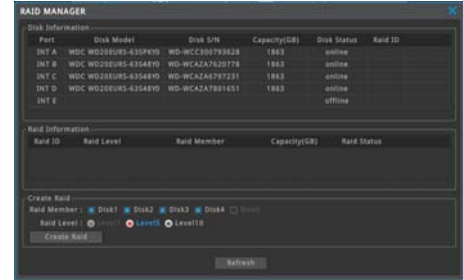

name	function description
Raid Member	Select disks that need to be in Raid.
Raid Level	Select Raid Level 1, Level 5, Level 10.
Create Raid	Create Raid with selected Raid Member and Raid Level.
Raid ID	Displays Raid ID.
Disk Status	Online : HDD is connected, Offline : HDD is not connected.

What is RAID?

- ✓ Webgate's DVR models(HD1600F-PDR, HD1600F-R, HD800F-PDR, HD400F-PDR) support RAID function via built-in hard disk.
- ✓ RAID(Redundant Array Independent Disk) can store the data using the pre allocated parity territory if there is an error in hard disk.
- ✓ Supports RAID 1, 5, 10 and auto restore function when replacing a defective hard disk.

Of hard disks and RAID construction methods.

- ✓ Depending on the # of hard disks installed in DVR, availability of RAID level will differ.
- ✓ Refer to the below table for supported RAID level.

HDD #	Possible Level	Actual # for recording	Capacity
2	RAID 1	1	100% (480fps)
3	RAID 5	2	50% (240fps)
4	RAID 10	2	100% (480fps)
5	RAID 5	4	50% (240fps)

How to deal with a problem occurred?

- ✓ If a problem was occurred during RAID operation, RAID manager will appear, and the faulty HDD state will be changed to Offline or Bad from Online.
- ✓ In this case, please turn off DVR and replace the faulty HDD with same capacitor's new HDD. If you turn on the DVR, DVR will start rebuilding automatically. Once rebuilding was started, it will keep rebuilding at background even if you exit the menu. Please note that completion of proper rebuilding can ensure the reliability of RAID system.
- ✓ Please be careful not to replace the normal operation HDD. If you replace the normal operation HDD, you could lost the data. Be sure to replace the faulty HDD only.

User settings

menu → system → user settings

DVR users will either be manager or user. Managers can use all functions of DVR without limitation and can set up user settings. Up to 10 users can be registered and each user can only use functions for which they've been given access to.

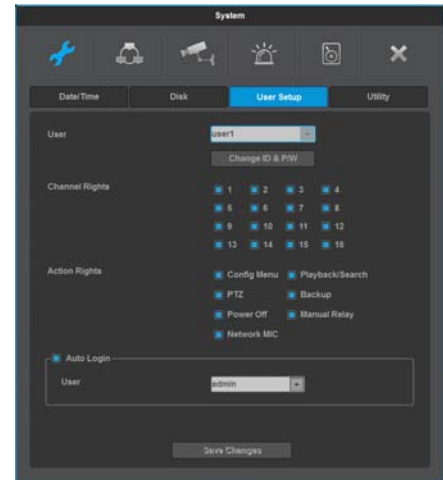

Channel access

A manager has an access to every channel.
A manager can give access to channels to each user.

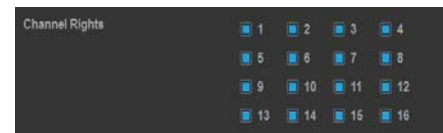

Function access

A manager has an access to every function and can give authority to each user to use functions(menu, PTZ, relay, playback, power off, copy, microphone)

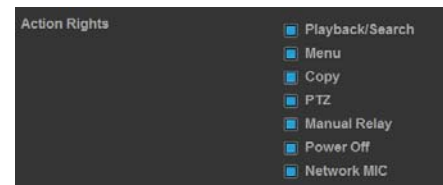

ID & password change

For User 1~10, max 20 and 8 characters are allowed for ID and Password.

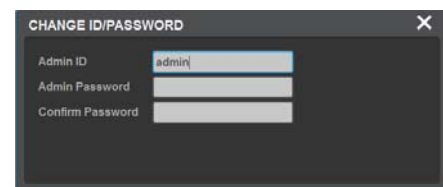

<reference>

Default manager Password is "12345" and for user 1 ~ 10, password will take a pattern of "11111" for user 1, "22222" for user 2 and so on. So user 10 will have a password of "00000". To enter 0, press "10" on the front panel.

Channel Authorization

A manager will send channel authorization and password to each user after completing channel authorization assignment per user on the channel authorization. Users can only use functions authorized by a manger

utility

menu → system → utility

Utility sets up DVR name, remote control ID, and language.

DVR alias

Set the DVR alias when connected to network.

language

select a language for a system.

DVR keyboard ID

This menu sets the address of keyboard when using all functions of DVR by keyboard. default value is "1". If user wants to control various DVR by one keyboard, its address should have different value. If designated address is configured the same as keyboard, user can control DVR function.

Remote control ID

Can set up max 255 remote control and all can be managed with a single remote control.

Firmware upgrade

Can update firmware by USB Memory stick

- Insert USB memory to USB port.
- Click firmware upgrade button.
- Click "yes" when a pop up box asks if a user want to upgrade a F/W via USB memory stick and that it will reboot the DVR.
- DVR will reboot after a while.
- Firmware upgrade via USB memory stick is completed.

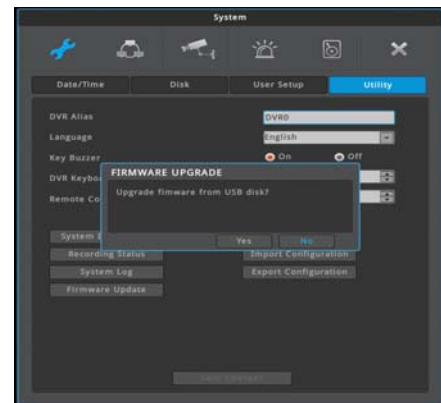
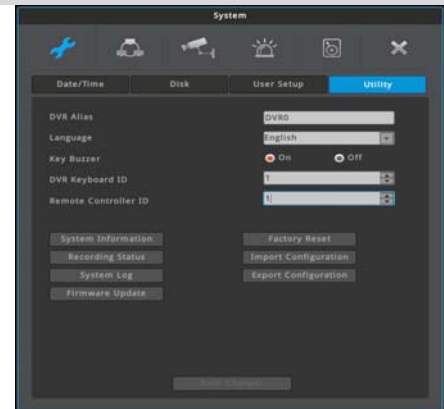

System log

System log shows the log list of system booting, user login, setting changes. User can scroll the list using up and down buttons on the front panel.

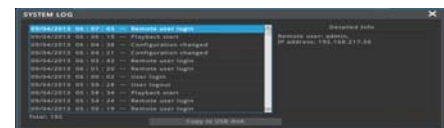

Factory reset

Change all set up values to default values.

Only a manager can use this function.

<warning>

Only a DVR system manager can use this function.

Refer to the (supplement – factor default value) for the factory reset.

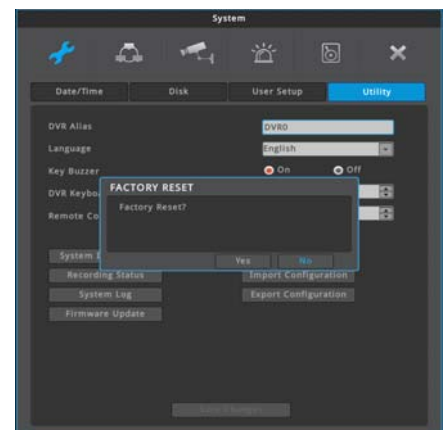

Configuration Import/Export

Export – Saves Configuration data in DVR to USB

Import – Apply exported Configuration data to relevant DVR or another DVR.

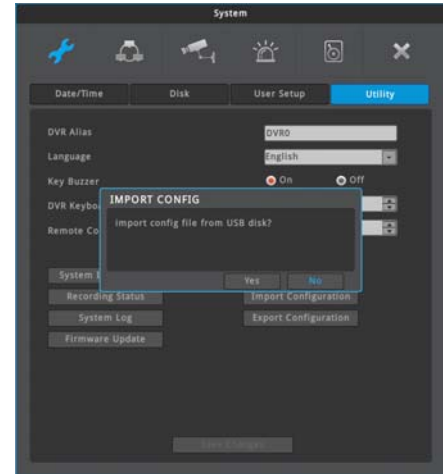

Recording status

Displays DVR recording status.

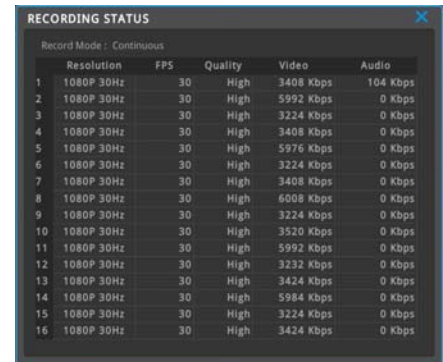

System info

Displays DVR system info



Network

Configure network info when DVR is connected to a network.

Network settings

menu → network → network → Ethernet

used to configure the relevant network info when DVR is connected to network.

type

Select Network type(Ethernet/xDSL). If DVR is connected to cable modem or lan, select "Ethernet".

If DVR is connected to xDSL, PPPoE type, select xDSL. But if it is not PPPoE type, even if it is xDSL, select 'Ethernet'.

DHCP

If Network to which DVR is connected has a DHCP server, it, assuming it is enabled, will automatically assign IP address to DVR.

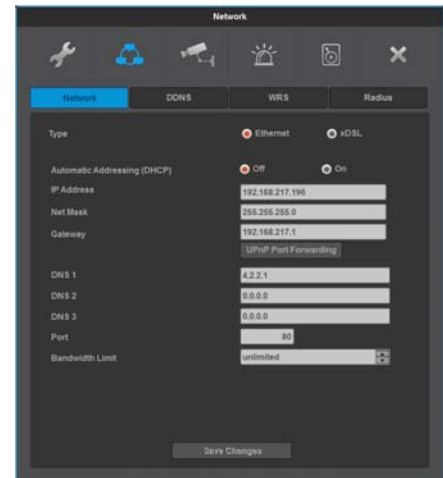

IP address

IP Address is for the connection between DVR and Control Center and also for web connection from Webviewer. (But, Net Mask, Gateway should be configured.).

Net Mask

Net Mask makes range of IP address available.

Gateway

Gateway address must be entered for DVR to connect to external network and gateway address is given by network administrator.

DNS server

DNS must be entered in order to use various networks such as, WRS, NTP, e-mail, and twitter. Contact network administrator for DNS address.

UPnP Port Forwarding

When using Internet Sharing device supporting UPnP, this function enable all connected DVR to do Port forwarding and they can be connected to Internet with IP address of Internet Sharing device.

- (1) Configure two DVRs with DHCP On.
- (2) Please, check if DVRs which are connected to Internet Sharing Device are allocated with official IP.
- (3) Configure DVR port of DVR(A) and DVR(B) as 81 and 82 individually.
- (4) Configure UPnP function of Internet Sharing Device as "ON".
- (5) Configure UPnP Port Forwarding function of DVR as "ON".
- (6) Please, check if Port Forwarding Status message is changed from "Not Available" to "Port Mapping is OK".
- (7) Finally, if user accesses DVR(A) with the IP address with port number 81 or DVR(B) with the IP address with port number 82, user can access DVRs.

Port

Register port # in DVR and use it to connect to control center or webviewer.

Default port is 80 and be careful in entering the port # when used with PPPoE modem and router.

Bandwidth limitation.

Bandwidth is to configure the maximum transmission speed. Its default value is unlimited and users don't have to set bandwidth value if there is no need to limit the network data size of DVR.

<warning>

Please consult DVR manager if you want to modify bandwidth value.

DDNS

menu → network → DDNS

Through Webgate's own DDNS service, WNS server, users can give a domain name to DVR. Using a PC, users can register for a membership and create a domain name even if they don't register at www.mycam.to.

If connected to DDNS correctly, users can connect to status and print connection successful message. If users choose to use Custom instead of WNS, they can register a domain name at www.dyndns.org or www.no-ip.org.

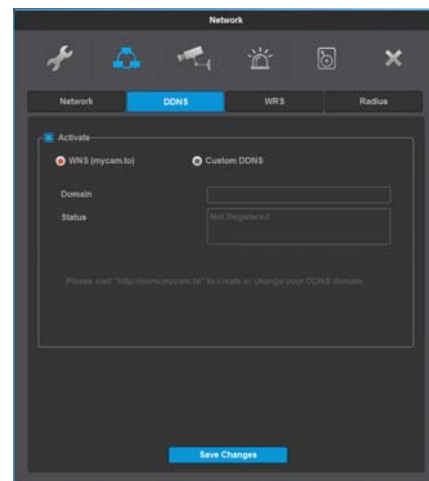

WRS

menu → network → WRS

If DVR is connected to a cable modem or xDSL model, IP address will change every time it tries to connect to ISP and users will not know the changed IP address. However, if DVR with flexible IP address is registered in WRS server, control center can easily access to the registered DVR despite changed IP address

Interval

WRS will renew its IP addresses in WRS server every 5 min if it is activated

group

Group name should closely be related to DVR.

Using a group name, users can find DVR connected to flexible IP on Control Center and connect it

URL

WRS website address is mycam.to.

Status

WRS server registration status of DVR

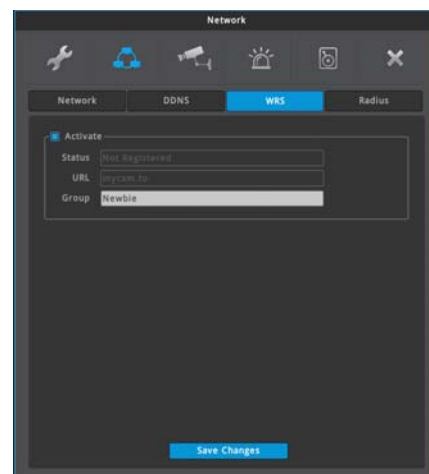

xDSL

menu → network → network → xDSL

DVR is connected to xDSL line and use PPPoE type, please change type by xDSL and configure user ID and Password. User ID and Password should be same as xDSL.

User ID/Passwor

Configure user ID and Password when DVR is connected to xDSL.

Status

It shows connection status of DVR.

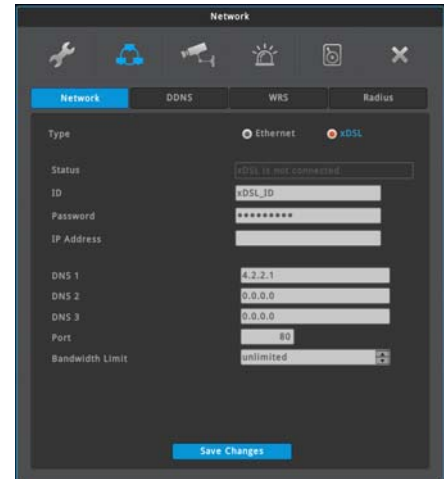

Radius

menu → network → RADIUS

Radius function manages many DVR accounts with one account using Radius server.

Radius menu configures status, IP address, and port. Status should be configured as enable in order to use Radius function. Port by default can use 1812 and if server assigns a port, then it needs to be configured..

'User ID', 'Password' and 'Radius Shared Key' are needed from administrator of Radius server after forwarding DVR account information to him. received 'ID/Password/Shared key' are used to register DVR at Control Center.

<warning>

please consult a server manager to use Radius function.

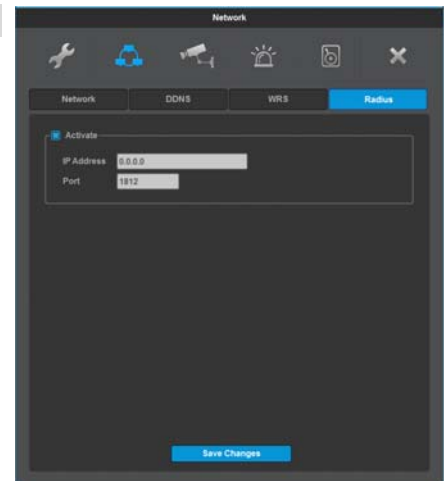

Device settings

In Device setup, user can configure camera, monitor, audio, text, serial which are connected to DVR.

Camera

menu → device → camera

At this menu, user can assign [camera name], and set each camera to use or not to use.

If the operator do not want live monitoring and recording for the video connected channels, the channels must be set as nonuse.

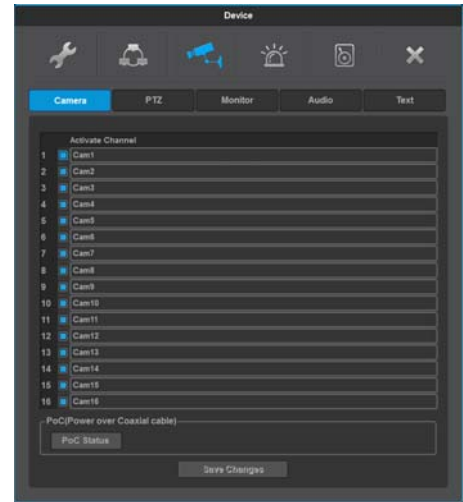

PoC Status*

Check the status of PoC camera & PoC adapter that are connected to DVR.

Reactivation

If there is an overcurrent in a channel to which PoC camera is connected, “thunder icon” will be displayed on the channel and will automatically shut off the power. Press reactivation to supply power after resolving an overcurrent problem.

Reactivation button will only be shown when there is an overcurrent and is hidden under normal settings.

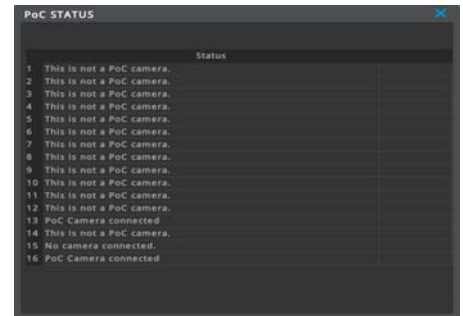

PTZ

Menu → Device → PTZ

Port

Choose one of COM2/COM3/CoC*.

Device

Select a device that is connected to the port.

Address

Select the device's address that is connected to the port.

Baudrate

Select the device's baudrate that is connected to the port.

* Please refer to page 5 for PoC/CoC

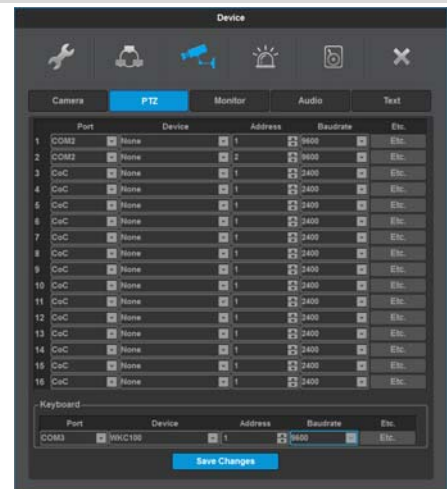

PTZ ETC

Auxiliary setting and Home Time can be configured.

Auxiliary

Auxiliary name and value can be set. Max. 16 Auxiliary settings can be registered.

Home Time

If there is no PTZ operation during the assigned time interval. PTZ moves to Home position.

Parity/Stop Bit/Data Bit

Configure as the same values of external device.

<Note>

COM1 is fixed as RS-232C port, and COM2/COM3 is fixed as RS-485 port.

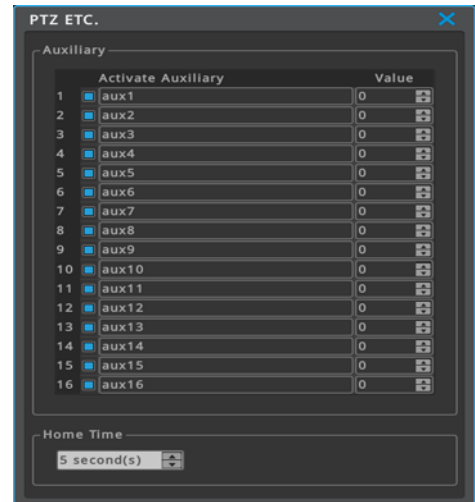

Monitor

menu → device → monitor

Configure SEQ, MULTI and event pop up.

alarm pop-up

If specific channel uses MD, Sensor Input, it makes the relevant channel pop-up as single or multi screen. To use this function, event should be set to event schedule in recording set up and MD / Sensor configuration should be done also.

If event popup time is configured "off", event popup will not work. Event pop-up can be configured per second from 1 to 10 seconds. If user set Event pop-up as keep, it will show continuously on the popup screen until the time user push any certain button

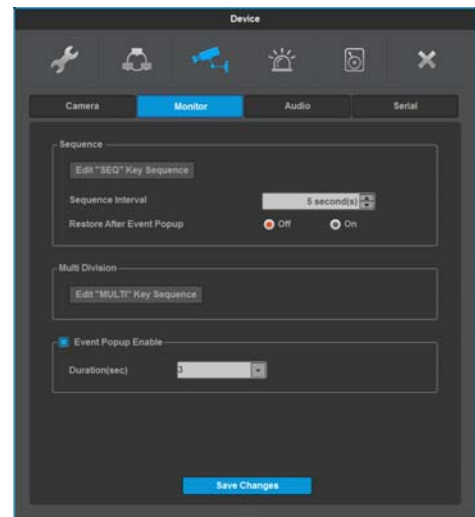

Sequence configuration

This menu is to edit function of user sequence configuration. User can configure 16 sequence modes and dwell time is available to set from 5 to 60 seconds.

For sequence mode, users can configure channel or division mode and sequence time from 5 to 60 seconds. If user set it to Off, this function will not work.

The default value of "Restore after Event-Popup" is off. If alarm popup occurs during sequence mode, sequence mode will be stopped under this condition. But, if "Restore after Event-Popup" is on, sequence mode will be activated again after alarm popup time finishes.

Sequence mode starts when user pushes [SEQ] button.

To escape from Sequence mode, please, push [SEQ] button one more time.



Multi set-up

Select multi screen order through multi set-up. Maximum of 16 screens can be set-up..

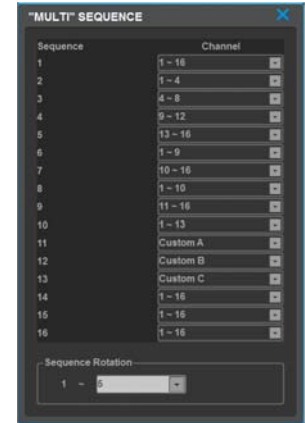

audio

menu → device → audio

Configure audio channel, audio recording, volume, synchronization, mixing on this menu.

Audio channel

Select a channel for audio.

Video channel

Configure if selected audio will be synchronized and heard through the video channel.

For example, if audio channel 1 is synchronized with video channel 4, then audio will be heard through video channel 4.

Save audio

If users want to save the audio in use. If set "off", audio will only be heard with live-video and if set "on", then audio will be heard during the playback

During playback, Audio is output together.

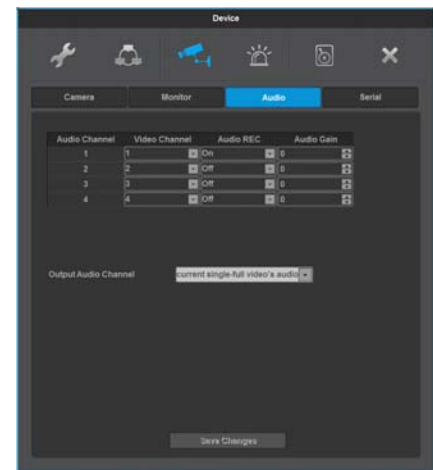

Text

menu → device → Text

Configures text info and click "Text" to configure the text.

Recording

Set On/Off of recording of Text input.

Sync Text with

Select channel to synchronize with text.

device (COM 1)

Choose from Manual, Star Finger 007, VSI Pro for text input device.

Star Finger 007 and VSI Pro can be used with defined protocol, and other devices with Manual mode.

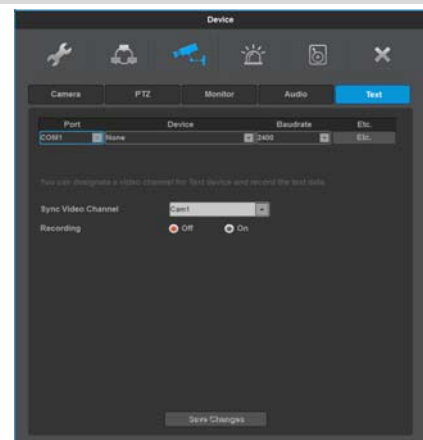

Manual Text Device Setting

Manual requires header/delimiter/lines/timeouts to be exact. Values for these are different for every device so please call the store you purchased the product from or refer to the manual.

Header check

If Text device is set manually and there is the text pointed out as Header, it is regarded starting of text information from the relevant letter. In case of not using Header, all text after Delimiter is regarded as new text.

Delimiter

It is a constantly inserted info to search for the end of the line. If DVR finds delimiter, it will see the place as the end of the line.

The number of Line

It is to define how many lines single information has. For example, if user sets 30 lines, system recognize single information binding 30 lines.

Time out

If configured line is not full, after the last information, if there is no further information during certain time range, system deal with it as one information.

Event Configuration

Event

menu → event → event

Event set up has 4 set up procedures, event, motion, sensor, and preset.

event

configures time range with event synchronization and can be configured as off, always, and custom

“always” recognizes and reacts to event when it is configured. “custom” can only use event during the time preset based on schedule settings

If custom is configured, event time can be configured per day/time through schedule setting window

If time isn't configured on custom or Off box is checked, DVR won't recognize any event and thus no event motion or event record will run.

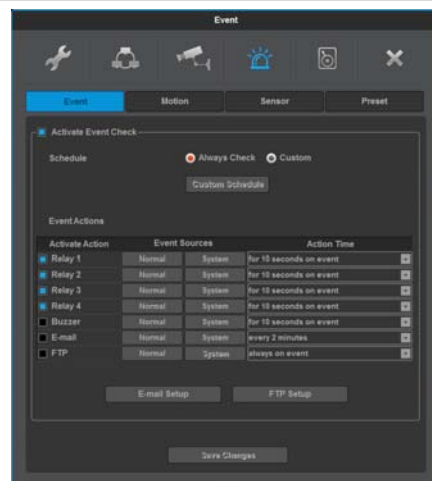

User schedule setting

If day/time are set, it will display on the graph right away. Select record begin/end time on the graph and click **them in order**, and the corresponding info will be displayed on day/time.

- day : set applicable day
- time : set applicable time
- register : schedule registration function
- delete : schedule unit delete function
- Clear : whole schedule delete function

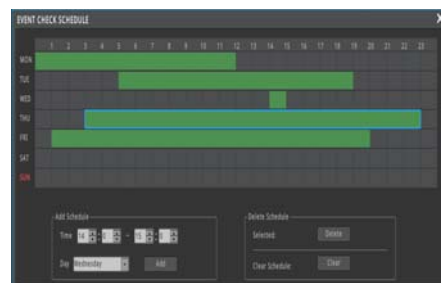

How to delete

Select item and click the Delete button.

If users click the delete button without selecting an item, previously selected item will be deleted.

How to delete all schedules

Click All Schedule Delete button.

sync event

Configuration for Event synchronization

Event action selection

Users can select relay, buzzer, e-mail, FTP and twitter.

Action Notification Duration

Duration of relay and buzzer will be the same as the time period preset by a user.

Transmissions will be sent to E-mail and Twitter at configured time interval.

If duration time is set off , Sync event will not work

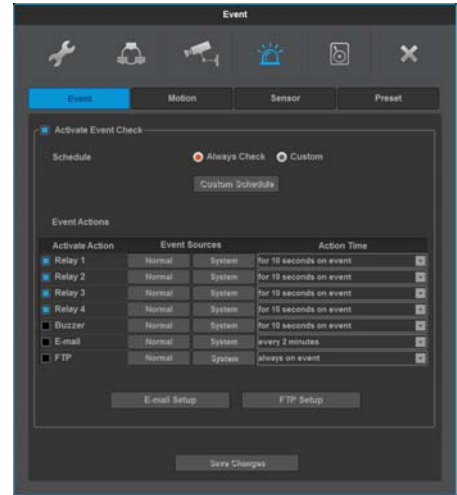

Average event source

Average event source can be configured as sensor, motion detector, V-Loss and text.

Relay

event will be notified through relay over the course of preset time duration.

Buzzer

event will be notified by buzzer over the course of preset time duration.

E-Mail set up

Users can use the function if they want to synchrozie event with e-mail.

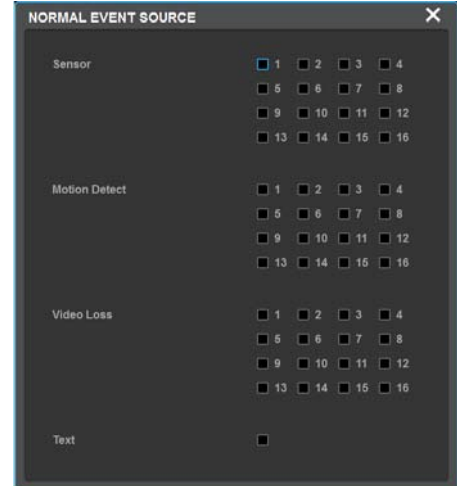

System event sourc

It can configure a part of or all of disk error, fan error, password error, WRS registration fail and power on.

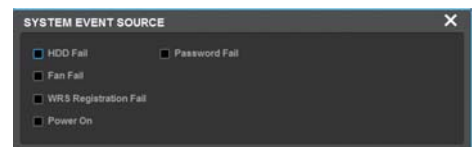

E-Mail Configuration

Recipient Address

Input E-mail address with receiver's E-mail info.

E-mail format should be xxx@xxxxx.xxx and the users must only use combination of numbers and the English letters

Sender's E-mail address

Sender's E-mail address is set when user use E-mail for output selection and user setup E-mail address as xxx@xxxxx.xxx.

Picture attachment

When sensor, motion detector and video loss occur, relevant event info with channel video will be sent to an e-mail. Only system event info will be sent for system event.

Authentication

There are 3 ways to send E-mail, Non-authentication sending, SMTP server authentication, TLS authentication. Non-authentication is to send e-mail without authentication from authentication server. SMTP server authentication is to send e-mail after an authentication of sender's e-mail address from SMTP server. TLS authentication is to send e-mail after an authentication of sender's e-mail address from TLS server.

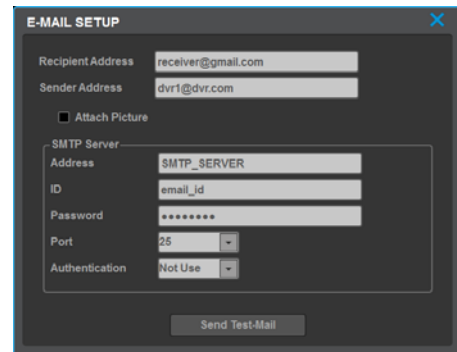

FTP Configuration

The DVR sends 1 video image per event to a FTP server when an event occurs.

<warning>

Since FTP just transmits an image, if there is no image system event, it is not supported.

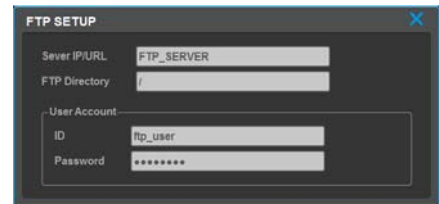

Server URL

Enter the FTP server address to send image

user ID

Enter the relevant ID when asked for FTP server authentication.

password

enter FTP server password.

FTP Directory

Select Folder to save image

If folder is not indicated, the image is sent to the folder which server selects

Motion detection

menu → event → motion

The Motion detection can be used to notify user of detected motion on each channel or all channel.

Channel

Configure All or each channel.

Sensitivity

Sensitivity can be configured from min.1 to max 10.

Area

Area configure detection when a motion is triggered.

User can select all or clear all. In case of configuring each channel, it is available to set all, clear all or define user area.

user area

When selecting a channel, user area can be configured.

1 grid size is **15x10** and factory default value is "All grid selected".

Press "change area" button to open motion detector enabled area set up window.

Users can set motion detection area in screen. The motion detection zone by setting is indicated in translucent green.

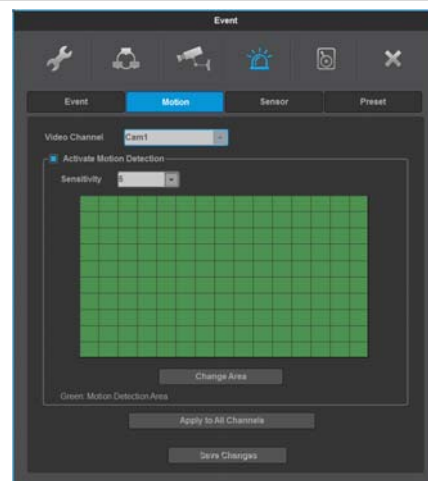

If an area is set up when motion detector set up start point is enabled, all values will be applied as disabled and if set up when motion detector set up start point is disabled, then all values will be applied as enabled. In other words, opposite set up to the value of the initially selected area will be applied.

sensor

menu → event → sensor

This menu is to setup the existing sensor input and the type of sensors. If sensor is selected as N.O, or N.C. it is applied to all channels. Users can set different options like N.O, N.C, or Off after selecting each channel.

Name	description
Normal Open	If sensor's electric contacts become connected, DVR recognizes it as an alarm.
Normal Close	If sensor's electric contacts become disconnected, DVR recognizes it as an alarm.

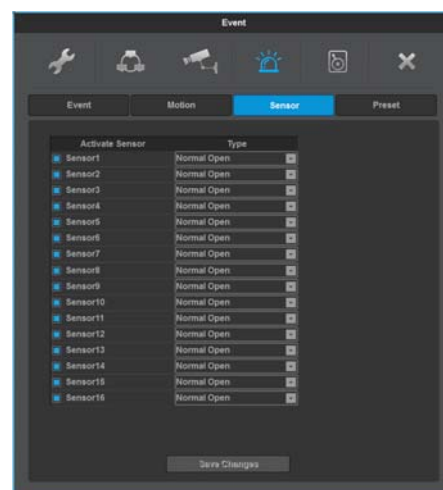

preset

menu → event → preset

In PTZ function, synchronize a specifically configured preset with event. Configure preset and select the event synchronized with preset. Event can select sensor, MD, Text, and up to 16 presets can be synchronized.

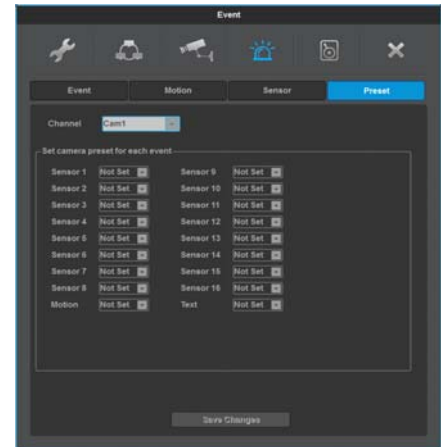

Recording set up

There are 4 modes for recording – schedule recording, manual recording, Continuous Recording, and Event Recording. Schedule Recording records automatically in accordance with the configured schedule and Manual Recording records via pushing “REC” button.

Continuous Recording records continuously upon initial system boot up. Event Recording records when an event occurs

Recording

menu → record → record

Users can select the recording mode from manual, continuous, or schedule recording.

And their resolution, frame rate, quality will be in accordance with the program Before recording set up, check the frame rate, video quality of a program per channel.

Manual recording

Manual recording will only run when recording mode is set at manual recording.

Manual recording begins when a user presses [REC] button on the product front after setting at manual record and selecting a program. To end the manual recording, press [REC] again.

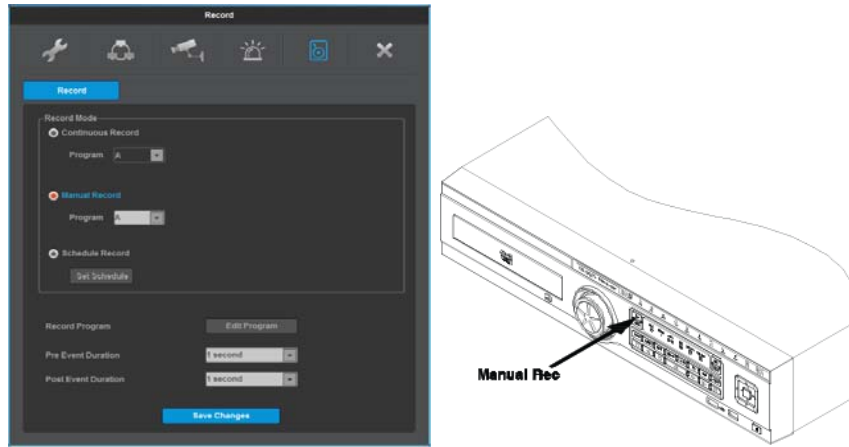

Continuous recording

Recording mode must be set at continuous recording and preset program will begin recording once booting is complete.

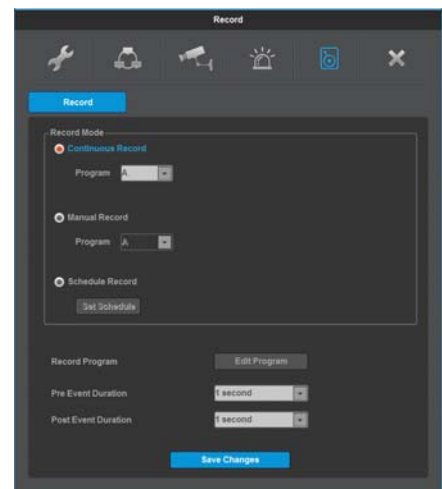

Schedule recoding

It records according to the programmed schedule automatically. select "Schedule record" and configure day and time

. Check and select each program default value and select one of 9 programs from A to I. User can not set two different program to one schedule.

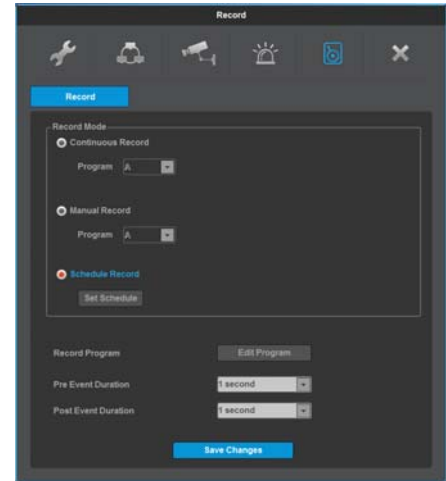

Configuration

Configure a program, time on a date and the info will automatically be displayed on the graph.

If select recording start/end time the table and click them in order and the corresponding info will be displayed



- Program : Set recording program(A~I)
- Time : Set time to apply
- Registration : Schedule registration
- Delete : Delete a schedule
- All Delete : Deletes the all schedules

deletion

Select items and click Delete button

If clicking delete button without item, previously selected item will be deleted from the latest time order. Clicking All Delete makes all schedule deleted.

<warning>

When configuring time sector, previously configured time can not be included.

Event recording

Event recording is a recording via "sensor", "motion detection", and "text" input.

To perform event recording, frame rate and video quality per program need to be set at program settings. By default, event recording synchronizes with 3 recording modes, continuous recording, manual recording and schedule recording.

<reference>

If user wants to use Event recording only, please, set frame rate as 0fps and enter frame rate for Event recording.

Event applied time

To make event record user needs to setup record time for pre and post event. Event record range will be set based on time set by user.

Record time before event

User can select between 1~5sec and time ahead of event will be recorded as much as time set by user.

Record time after event

User can select between 1~30mins and time after event will be recorded as much as time set by user

program

menu → recording → program

Using [Program], adjust frame rate and quality configure recording program for Continuous, Manual, and Schedule recording.

Select Program to configure frame rate & resolution. For maximum performance, user can freely allocate the recording resource per channel. This feature enables the user to lower the recording performance of each channels and allocate the remaining resources to raise the recording performance of a specific channel or channels.

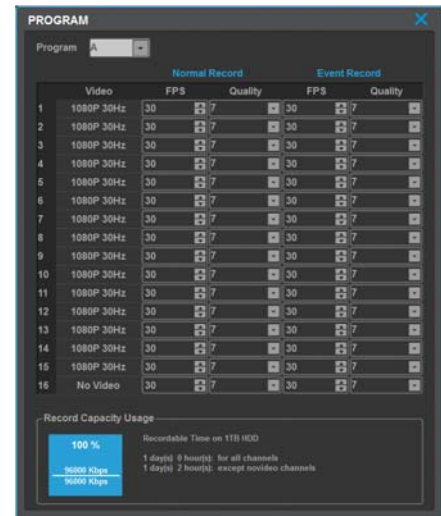

Program

There are 9 programs from A to I composing recording quality and resolution per channel.

Channels

Display the channel No.

video

displays entered video resolution and FRP.

Normal Recording

Configure the framerate and video quality of general recording (Manual/Continuous/Schedule).

Event Record

Configure the framerate and video quality during Event recording. Even though system is recording under Manual recording mode, if event occurs, system will record in accordance with Event recording configuration.

FPS

FPS (frames per second) users can select 1 to 30fps per second. Max. Frame can be changed according to the configuration.

Quality

This configures the recording quality. Value of Q can be configured between 1-10. The higher the number, the better recording quality is.

Record Capacity Usage

Displays the DVR recording quality.

Web Viewer

WebViewer is Web application program loaded to monitor real-time image or to monitor the images recorded through Web browser to PC located remotely.

System requirement

Items	Recommendation
CPU	Core i5 3.0GHz
Main Memory	4GB
Video Memory	512MB or higher
Display	1024MB PCI-E Graphic Card Support AGP Accelerate
BUS	Support PCI-E 16X or higher
Network	100/1000 Ethernet NIC
OS	Windows XP Professional(SP3 or higher) / Windows 7
Browser	Internet Explorer 8 or higher
Others	DirectX 9.0 or higher

installation

Webviewer Installer

Auto installation program is provided from login page to use Webviewer function. ActiveX installation is required to a PC which has first connection.

<caution>

Please close all programs related to Control Center while Webviewer Installer is being installed. Otherwise, it may affect the installation.

login

After inputting an IP address that is set to the system, the WebViewer Login page will be connected. Examples of input method in address box are <http://192.168.1.100> as IP address type or www.addressstest.com as domain address. In case of changing the port value besides default value 80, just input the changed port value.

Input the set of User ID & Password, click 'LOGIN' to access. If password didn't change in Control Center, ID and Password will be admin/12345.

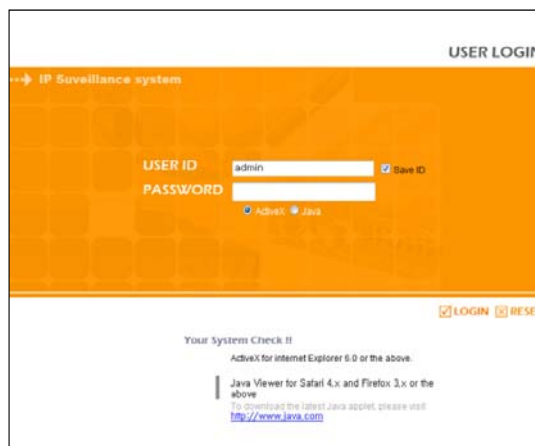

User set up

To access WebViewer, user authority and password can be changed in DVR or the account menu of Control Center configuration.

Monitor

When it is authorized with User ID & Password input at Login page, it moves to monitor page. At Monitor page, monitor real time image of cameras connected to DVR, or it can control PTZ camera, Relay, and use Microphone function according to user's authorization.

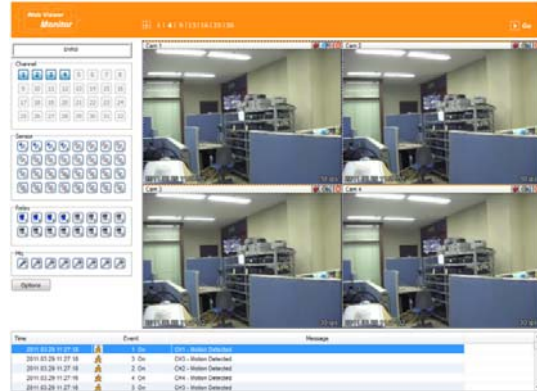

screen division and changing video position

The first monitor page will display the maximum screens of the connected model.



It can to change to 1, 4, 9, 13, 16, 25, 36 divisions by clicking the number on top of page. Also, it can change to 1 channel mode by click any one of channel image.

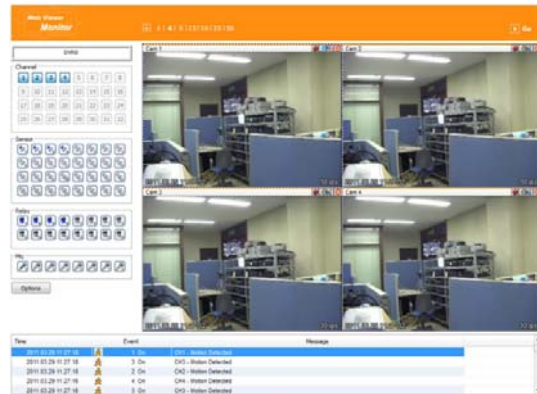

Double click on one of the playback screen to convert in 1 channel mode

1 After conversion to 1channel mode, double click on screen to return to previous division channels.

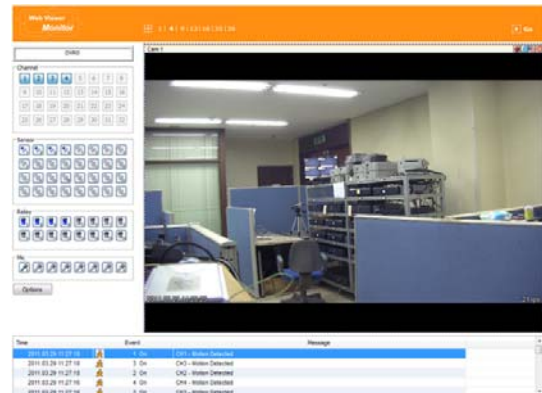

At division screen, it can change screen location using mouse drag

If Ch3 image moves to Ch1, drag Ch3 image and drop on Ch1 location so as to exchange between 3ch and 1ch image.

Press the very front icon on the upper screen on multi screen mode to switch to a full screen mode. To go back to normal screen mode from full screen mode, press ESC key

Move to Playback

Click the  on the upper right to move to playback page.

channel On/Off

It is On/Off button for the Channel located to left in page. Click the channel wanted to On or Off. And Default is "On".



Sensor indication

The icon indicates when sensor occurs in system

When it sensors, relevant sensor icon comes to Red, and indicates sensor number of video. When sensor is not triggered, icon keep as blue.



Relay operation

It can On or Off Relay of the unit. Click the number button to activate Relay On, then the icon Changes from Blue to orange color.



Not activated Relay button means, the product is no supported. Relay is need user's authority. Refer to user manual in the unit for the setup of User's authority of Relay.

Using microphone

Microphone can be set On or Off. Default is Off and it is changed from the projected type button to orange when click the button for the use Mic.

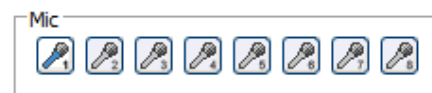

Event information

Time	Event	Message
2011.03.29 11:27:18	1 On	CH1 - Motion Detected
2011.03.29 11:27:18	3 On	CH3 - Motion Detected
2011.03.29 11:27:18	2 On	CH2 - Motion Detected
2011.03.29 11:27:16	4 On	CH4 - Motion Detected
2011.03.29 11:27:16	3 On	CH3 - Motion Detected

It shows real time event data occurred at the bottom of monitoring page. Indicated Event data list are as follow

button	description
	Motion Detect On
	Sensor Input
	Relay Output On
	No Video, Video Detected

video recording & save

video recording

Select by clicking "Rec Start" in right button of Mouse after selecting channel user wants to record during monitoring. It can record max. 10 minutes of video During Quick Recording, recording time is indicated on video.

If "Rec Stop" is pressed by clicking right mouse button, recording stopped. Then, open the dialogue box to store recorded files. At this time, user can save it to the directory with any file name by user.

Saved recording file is saved into "*.re4" file format. re4 file can playback through Control Center Playback program or Mini Player program.



saving video

There are 3 types for saving Video - jpg, bmp, eye, saving means the function to record 1 frame of current monitoring channel.

To save video, select the channel and click right button of mouse. and select "Save As" and point out the location and press Save button.

Using PTZ

During monitoring, select a channel with PTZ configuration and right-click to select "PTZ" to use PTZ. PTZ control lets users use Pan/Tilt, Zoom/Focu functions.

Pan, Tilt control

There is a cross line in the middle and click image to operate Pan, Tilt. In the middle click Left/Right direction to control Pan, and Click Up/Down direction to control Tilt. The further it is clicked from the middle, the faster Pan/Tilt will operate.



Zoom, Focus control

Move mouse to the edge of left & right to see slide bar for Zoom, Focus.

The unit Area Zoom In available has Zoom Zero operating button. It can zoom in/out using slide bar at left of image, left slide bar can control Focus.

Move to Preset

In case of Preset set, Mouse on image press right button for pop-up menu and "Goto Preset" is indicated additionally. When select Preset list, it moves to Preset position selected. Preset should be set up by user in advance.

Activating Auxiliary

In case of Preset set, "Auxiliary" is indicated additionally, and it operates action when select registered menu.

<Reference>

Supported PTZ camera list can be refereed to (PTZ manipulation).

Using Audio

In case of Channel setup sync with Audio, press right mouse button on the image to activate pop-up menu to "Listen" and uncheck Mute. Audio Value adjustment is available using slide bar.



Playback

This page is to playback recorded images, and user who has authority of 'HDD' among user ID or administrator can use this function.

Playback that is made up 16 divisions can play the images by searching through colander by recording period and moving the period. It can backup recorded image and also print Pause image or save to Bmp file.

Below are each title and function of Playback.

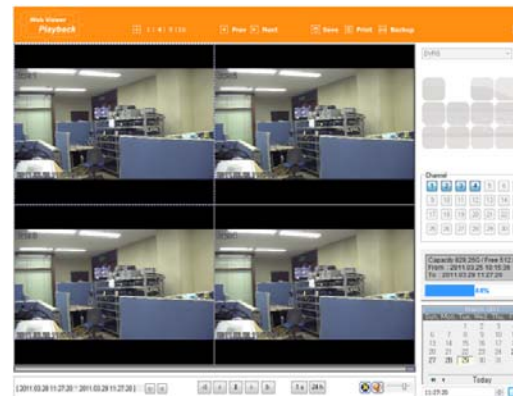

Video Division & Changing Channel



Playback supports 1, 4, 9,16 divisional screens. select division using menu on top of page as shown in the above picture.



Press the very front icon on the upper screen in multi-screen mode to switch to a full screen mode. To back normal screen mode from full screen mode, press ESC key.

Save image



It can save playback image to BMP file. Click mouse to channel to save. Dotted line will be surrounding to the selected channel, and click 'Save' button

Save image dialog box appears, then it can input message or select channel name, date, event and data.

Press 'OK' to open dialog box for the saving location, then save

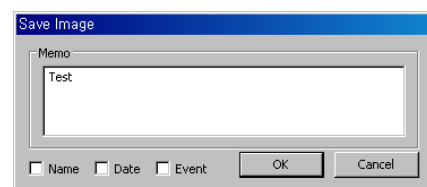

bmp file.

Print

Select image with mouse for the channel to print image saved, and then click 'Print' button.

Window comes to input Memo, and click 'OK' button to print the image through the printer connected.

Print material includes 'Printing Date', 'Channel name', 'Recording Date', 'Event', 'Memo'.

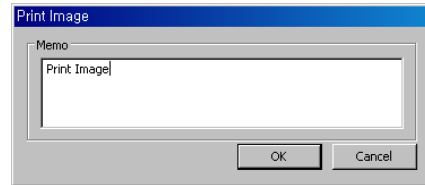

Back up

There are re4 (Multi channel) and avi(single channel) Set From, To time and select the channel for backup

Point out the location for backup. Input in Password/Verify.

In case of playback backed up file, correct password should be input.

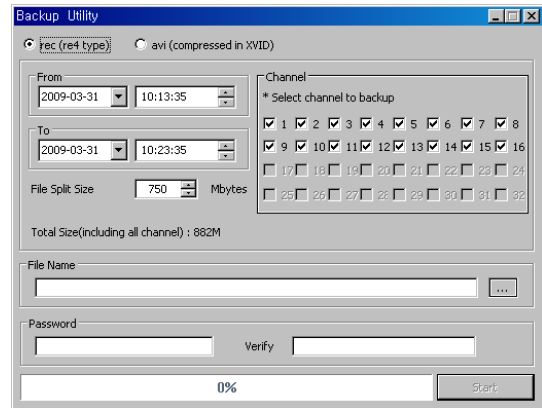

Move to Web Monitor

Click 'Go' button at top of page, and it can move Web monitor page.

channel On/Off

same function as the Channel On/Off function at Web Monitor.

Located on the right, and click the wanted channel to "On" or "Off". All channels are On by Default.

Disabled Channel button means the product doesn't support it.



Saving time & Checking Record Capacity

Displays the used and remaining space of HDD and the dates on which the first recording and last recording were done. It also shows in % how much space a user is using.

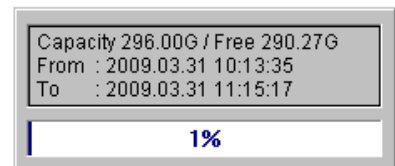

Calendar search

Recorded date is enabled in black color, and others unrecorded date disabled in grey. Click [Go to] button after select date & time so as to playback images on the date & time selected.

[2011.09.27 17:30:47 ~ 2011.09.28 17:30:47] <- ->

'When clicking the 'Go To' button, it indicates for 24hours from the time selected at left bottom. As above picture, it is possible to change the time zone with '24h' button.

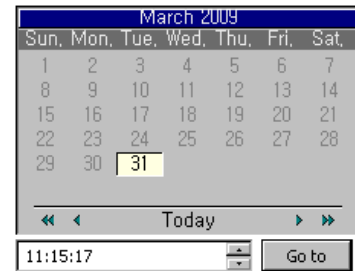

Function buttons on the bottom of an image



- ① Indicates playback range of recorded image.
- ② Press <-> button as the time set at (5) so as to change the time zone to playback in forwarding and reversing.
- ③ From left button, it can 'Move a frame back', 'Play backward', 'Stop', 'Play', 'Move a frame forward'.
- ④ It is the function to set play speed. After click the button, it can set the play speed '0.5x, 1x, 2x, 4x, 16x, 32x, 64x, and All'.
- ⑤ It is the function to set play area. After click the button, it can select play area '10min, 30min, 1hour, 3hour, 6hour, 12hour, 24hour'.
- ⑥ It can select DirectX use or not. If check DirectX mode, it can play image into Direct Draw based on graphic card and performance of PC.
- ⑦ It is the function to set audio play or not, and volume

JAVA Viewer

Java viewer, similar to Safari, Chrome, Firefox, is a web viewer which lets users access to and monitor DVR on web-browsers which don't support ActiveX provided by Microsoft Internet Explorer.

Java should be installed in login screen to use Java viewer

After an installation of Java manually, select "Java" in below of Password window and login.



After the login, single screen of video channel 1 is displayed.

Multi-screen display, Event, Relay can be used in Java viewer. To change Multi screen display, click 1,4,9,16 in right side.



Mobile Viewer

Mobile viewer is an Application for Smart Phone. It is available to search and install as free of charge with "WebEye" keyword in **Apple App store** & **Google Android Store**.



- ✓ Available to register up to 16 units
- ✓ Supports single/ 4 divisional monitoring mode.
- ✓ Supports multi-stream function
- ✓ Able to search system and event logs.
- ✓ Supports Digital Zoom, PTZ Control, Image saving, Image e-mail sending, etc. in Single Monitoring Mode.

appendix

problem solving [FAQ]

problem & symptom	solution
If system power isn't on, LED on the system front won't operate	<ul style="list-style-type: none">✓ Check the power of system✓ Check power voltage in out✓ Check or replace power supply if power doesn't turn on after above procedure
No video on some channels with black screen	<ul style="list-style-type: none">✓ Check the camera connected with relevant channel. Occasionally, the symptom may occur if camera video doesn't input correctly.✓ Check if power is supplied to camera correctly.✓ Occasionally, the symptom may occur with weak video signal from video distributor when the video is connected with variable systems. In this case, the symptom can be figured out/ solved connecting the camera directly to DVR.
No Video on Screen	<ul style="list-style-type: none">✓ Check cable between DVR and camera✓ When camera is connected to HD-SDI BNC input : Check if camera support HD-SDI output✓ When HD-SDI BNC output is connected to Monitor BNC directly : Check if monitor support HD-SDI input✓ When HD-SDI video is changed through DVI, VGA, etc. thru video converter : Check if video format of converter's HD-SDI input support s video format of this product.
REC LED doesn't turn on despite pressing [REC] button in front panel and No recording.	<ul style="list-style-type: none">✓ Check if HDD space is secured to record✓ Check if recording mode is set in menu
Only logo screen shows repeatedly	<ul style="list-style-type: none">✓ Main board has a problem or SW is damaged. Please contact CS team for a further check.
Channel button doesn't work in live screen.	<ul style="list-style-type: none">✓ If current screen is for event use, channel doesn't work. In this case, please terminate event screen pressing [ESC] and select channel.
Cursor doesn't move in Calendar Search.	<ul style="list-style-type: none">✓ Check if marked at channel and date you want playback✓ Both channel and date should be checked to start playback.
Alarm doesn't stop in spite of pressing [ESC] button to delete after an alarm is triggered.	<ul style="list-style-type: none">✓ Please delete alarm pressing [MENU] in front panel as follows.<ol style="list-style-type: none">1) Withdrawing event monitoring screen : Monitoring mode – It turns off event monitoring time duration.2) For alarm sound cancel : Event record mode - Alarm (Motion

	<p>detection/Video loss) – It erases alarm output.</p> <p>3) For event cancel : Event record mode - Alarm (Motion detection/Video loss) – It turn off mode.</p>
No response in Live screen even [PTZ] button is pressed.	✓ Check if connected protocol and other configuration is set correctly for PTZ camera in Menu -> Network -> Remote Device.
External HDDs are not recognized as quantity installed physically after connecting multiple external HDDs to DVR.	✓ It takes time to be recognized multiple external HDDs. Try it again later. If same problem goes on, it is highly originated from HDD problem. Please try it with other HDD
Time re-setting is required" message comes out on the screen.	✓ This message comes out when there is time setup error on built-in clock. Please contact local dealer for further support .
"NONE" icon and error message pops up.	✓ Please check HDD connection status. Please contact local dealer if this message continues to pop up even if there is no problem in connection.
There is no added information of HDD after installing additional HDD.	✓ Please check if additional HDD is compatible with DVR. To know more about compatibility, please contact CS team of manufacturer.
There is no added information of external storage devices (USB memory, eSATA HDD)..	✓ Please check if additional storages are compatible with DVR. To know more about compatibility, please contact CS team of manufacturer.
Network setup using router is difficult.	<ul style="list-style-type: none"> ✓ Please refer to product manual for details ✓ Please refer to UPnP section under "Network connection and setup" if a user is using router for network connection.
Lost password.	✓ Please contact CS team of manufacturer.
Copied data is not played in the PC.	<ul style="list-style-type: none"> ✓ Please don't remove media during copy or don't turn off DVR. ✓ VFS4 (For DVD copy), exe copy is for customized player only so it can be played using MiniPlayer. ✓ Please install multi codec for playback data copied in avi format.
Can't return to live mode during playback.	✓ Press [□] or [live] button in front panel or remote control to return to live screen.
Recording is not working.	<ul style="list-style-type: none"> ✓ Please check if camera input is well connected ✓ Please check record mode. ✓ Please check HDD is ready for record. ✓ Please check if current time is included in scheduled record time in case record mode is continuous or event. ✓ Please press [REC] button to start record. ✓ In case event record is not working please check event detection status.
Recorded picture quality is not good.	<ul style="list-style-type: none"> ✓ Please set picture quality as Q7 for 1080p, Q5 for 720p. ✓ In case resolution and recording picture quality set high, data size

	will become high accordingly so HDD capacity will be reduced too. It will lead to short period time of recording
Remote control doesn't work.	<ul style="list-style-type: none"> ✓ Point to remote control receiver ✓ Get new batteries.

compatible HDD

Please ask to seller for the HDD list compatible with DVR.

Factory default set-up values

System				
Date/time	Time		Current time	
	Time zone		UTC 00:00 Dublin	
	Daylight Saving Time (DST)		off	
	Set Custom DST	type		Use Day of Week
		Start time		Jan / Last / Sun / 0:00
		End time		Feb / Last / Sun / 0:00
	Date Format		Month/Day/Year	
	Sync With NTP	NTP Enable		Off
		NTP Mode		Client
		NTP Location		Public
NTP Local			0.0.0.0	
Interval			1 hour	
Disk	Disk manager			
	RAID manager			
	Overwrite		On	
	Disk Full Alarm Warning		75%	
	Block Playback		off / 5Day	
	Delete Data		off	
User Setup	User		admin	
	Change ID & PW			
	Channel Rights		All Select	
	Action Rights		All Select	
	Auto login		Turn on / admin	
Utility	DVR Alias		DVR0	
	Language		English	
	Keyboard sound		on	
	DVR Keyboard ID		1	
	Remote Controller ID		All	
	System info			
	Save status			
	System log			
	Firmware upgrade			
	Configuration setting initialization			
Import configuration				
Export configuration				
Network				
Network	Type		Ethernet	
	Automatic Addressing (DHCP)		Off	

	IP Address		192.168.0.2	
	Net Mask		255.255.255.0	
	Gateway		192.168.0.1	
	UPnP Port Forwarding		off	
	DNS		4.2.2.1 / 0.0.0.0 / 0.0.0.0	
	Port		80	
	Bandwidth Limit (Mbps)		unlimited	
xDSL	ID		Guest	
	Password		*****	
	Status		xDSL is not connected	
DDNS	activate		Turn off	
	status		Not registered	
	URL		mycam.to	
	group		none	
WRS	Enable		off	
	Status		Not registered	
	WNS (mycam.to)		On	
	Custom DDNS		off	
	Domain		None	
Radius	Enable		Off	
	IP Address		0.0.0.0	
	Port		1812	
Device				
Camera	status		turn on	
	Name		Cam 1 ~ 16	
PTZ	port		CoC	
	device		C1080	
	address		1	
	baudrate		57600	
keyboard	port		None	
	device		WKC-100	
	address		1	
	Baudrate		9600	
Etc	Auxiliary Enable		on	
	Home time		off	
	Parity bit		None	
	Stop bit		1	
	Data bit		8	
Monitor	Edit "SEQ" key sequence	SEQ 1~16	Cam 1~6	
		SEQ Rotation	1~4	
	Interval		5 (Sec)	
	Restore after Event popup		off	
	Edit "MULTI" Key Sequence	SEQ Rotation	1~5	
	Event Popup Enable		off / 3sec	
	Audio	Audio channel		channel 1 ~ 4
		Video channel		Channel 1 ~ 4
Audio REC			off	
Audio Gain			0	
audio output channel			current singl-full video's audio	
Text	Port		COM1	
	Device		None	
	Baudrate		2400	
	Sync Video Channel		Cam1	

Recording		Off
Etc	Parity bit	none
	Stop bit	1
	Data bit	8
Manual	Header check	off
	header 1	None
	header 2	None
	delimiter	0DOA
	Time interval(ms)	1000
	# of lines	20

Evnet

Event	activate		Turn on	
	Event check		always	
	Event synchronization	Relay 1		Turn on
			Normal event source	turn off all
			system event source	Turn off all
			Duration period	10 seconds
		relay 2		Turn on
			Normal event source	Turn off all
			system event source	Turn off all
			duration period	10seconds
		Relay 3		Turn on
			normal event source	Turn off all
			system event source	Turn off all
		Relay 4		Turn on
			normal event source	Turn off all
			system event source	Turn off all
		buzzer		Turn off
			normal event source	Turn off all
			system event source	Turn off all
			duration period	10seconds
		Email		Turn off
			normal event source	Turn off all
			system event source	Turn off all
			duration period	2mins
		FTP		Turn off
			normal event source	Turn off all
	system event source		De-activate	
	duration period		immediately	
	E-mail configuration	sender address		receiver@gmail.com
		Receiver address		Dvr1@dvr.com
		attach		Turn off
		SMTP address		SMTP_SERVER
		SMTP ID		email_id
		SMTP Password		*****
		SMTP port		25
SMTP Auth			Not Use	
FTP configuration	server IP/URL		FTP_SERVER	
	FTP channel		/	
	ID		ftp_user	
	Password		*****	

Motion	channel		Cam1	
	activate		Turn on	
	Sensitivity		5	
	Area		All Select	
Sensor	activate		Turn on	
	Sensor		Normal Open	
Preset	Channel		Cam1	
	Preset	S1~S16	None	
		Motion	None	
		Text	None	
Record				
Record	Record Mode		Countinuous	
	Program		A	
	Pre Event Duration		1	
	Post Event Duration		1	
	Program	Program	Program	A
			Normal FPS	30
			Normal Quality	7
			Event FPS	30
			Event Quality	7

* Varies between different models

Product specification

HD1600F-PDR

VIDEO INPUT

Video input standard	SMPTE 292M (HD-SDI) DoubleReach™ support for 8 channels
Resolution / Frame Rate	SMPTE 274M (1080p, 1920x1080) : 25, 30, 29.97 FPS Input format auto detection
Connectors	16ch, 75Ω BNC connector
PoC	16ch, Power over Coax, Max. 16 W/ch, Total 180W
CoC	16ch, Control over Coax, Max. 57,600bps

VIDEO OUTPUT

Video output	HDMI
	1, 4, 9, 10, 13, 16 split-screen
	User defined sequence / Alarm pop-up
	1920 x 1080p via HDMI port

RECORDING

Compression	H.264 / JPEG
Resolution	1920 x 1080
Rate	400/480 fps at 1080p
Quality	1080p, 10 levels up to 12Mbps
Mode	Manual & Event / Schedule & Event / Continuous & Event
Schedule	24hrs / 7days

PLAYBACK

Mode	Instant playback / search
Speed	Max. 400/480 fps at 1080p
Search type	Time, Calendar, Timeline, Event, Thumbnail, Smart, Text
Block playback	24hours ~ 99days

EVENT & ALARM

Event source	MD(Motion Detection), Sensor, Text, Video Loss
Event check Schedule	24hrs / 7days
Event action	Buzzer, Relay, E-mail, FTP, Alarm pop-up
MD area	15 x 10
Sensor input	Dry contact (NO or NC selectable)
Text input	POS/ATM support, AVE VSI Pro/Hydra support

SYSTEM ALARM

Alarm source	HDD fail, HDD almost full, Fan fail, Password fail, WRS fail
Alarm action	Warning message, Buzzer, E-mail, Relay

AUDIO

Input/output	Input 4ch RCA / output HDMI, RCA
Compression	16KHz, 16bit sampling ADPCM
Direction	Both

PTZ

Protocols	35 models including C1080, C1080PT-Z20, Pelco-D, Pelco-P, Samsung, Panasonic and others
-----------	---

NETWORK

Interface	1 Gigabit Ethernet (10/100/1000Mbps)
Type	Static IP, Dynamic IP, xDSL
DDNS	WNS, DynDNS, NoIP, WRS
Bandwidth limit	Supported
NTP	Server / Client / Both
Users	10 Monitoring, 2 Playback
Streaming	1 HD, H.264 stream, Same as recording setting
	1 additional H.264 stream, nHD(640 x 360)
	1 JPEG stream, nHD(640 x 360) for e-mail or mobile

SECURITY

User level	1 admin, 10 users
User privilege	Menu, PTZ, Relay, Playback, Power, Copy, Network MIC
IP filtering	Supported

STORAGE & BACKUP

Storage devices	5 internal SATA HDDs, 1 external eSATA Interface, 1 Gigabit network for storage(NS0104R)
RAID Level	1/5/10 Supported
File system	Proprietary file system, Data-loss protection against power-failure
Capacity	Max. 16TB with eSATA, Max. 128TB with cascaded NS0104R
Backup type	Multi-channel or Single channel avi file
Backup device	USB drive (2 ports)
S.M.A.R.T.	Temperature and Health checking

SERIAL & I/O

Serial port	1 RS-232C, 2 RS-485
Sensor input	16 Dry-contacts
Relay output	4 Relays

CONTROLLER

Device	Front panel, IR remote, Joystick Keyboard, Mouse
--------	--

SOFTWARE

Web viewer	Monitoring / Event / PTZ / Playback with IE
Java viewer	Monitoring / Event / PTZ with IE, Chrome, Safari
Mobile viewer	Monitoring / PTZ / LogView with iPhone & Android
CMS	Control Center Standard, Max. 1024 DVRs
SDK	ActiveX(COM) SDK

ENVIRONMENTAL & PHYSICAL

Dimension	445(W) x 418(D) x 88(H) mm
Weight	10 Kg (No HDD)
Operating Temperature	5°C~45°C (41°F ~ 113°F)
Power	AC free volt (100 ~ 240VAC), 50/60Hz
PoC Power	DC 24V/7.5A (Option)
Power Consumption	Max. 100W Typical 70W(1 HDD)
Approval	KC, FCC, CE, RoHS, HDcctv(TBD)

HD1600F-R

VIDEO INPUT		NETWORK	
Video input standard	SMPTE 292M (HD-SDI)	Interface	1 Gigabit Ethernet (10/100/1000Mbps)
Resolution / Framerate	SMPTE 274M (1080p, 1920x1080) : 25, 30, 29.97 FPS Input format auto detection	Type	Static IP, Dynamic IP, xDSL
Connectors	16ch, 75Ω BNC connector	DDNS	WNS, DynDNS, NoIP, WRS
VIDEO OUTPUT		Bandwidth limit	Supported
Video output	HDMI	NTP	Server / Client / Both
	1, 4, 9, 10, 13, 16 split-screen	Users	10 Monitoring, 2 Playback
	User defined sequence / Alarm pop-up	Streaming	1 HD, H.264 stream, Same as recording setting
	1920 x 1080p via HDMI port		1 additional H.264 stream, nHD(640 x 360)
RECORDING		1 JPEG stream, nHD(640 x 360) for e-mail or mobile	
Compression	H.264 / JPEG	SECURITY	
Resolution	1920 x 1080	User level	1 admin, 10 users
Rate	400/480 fps at 1080p	User privilege	Menu, PTZ, Relay, Playback, Power, Copy, Network MIC
Quality	1080p, 10 levels up to 12Mbps	IP filtering	Supported
Mode	Manual & Event / Schedule & Event / Continuous & Event	STORAGE & BACKUP	
Schedule	24hrs / 7days	Storage devices	5 internal SATA HDDs, 1 external eSATA Interface, 1 Gigabit network for storage(NS0104R)
PLAYBACK		RAID Level	1/5/10 Supported
Mode	Instant playback / search	File system	Proprietary file system, Data-loss protection against power-failure
Speed	Max. 400/480 fps at 1080p	Capacity	Max. 16TB with eSATA, Max. 128TB with cascaded NS0104R
Search type	Time, Calendar, Timeline, Event, Thumbnail, Smart, Text	Backup type	Multi-channel or Single channel avi file
Block playback	24hours ~ 99days	Backup device	USB drive (2 ports)
EVENT & ALARM		S.M.A.R.T.	Temperature and Health checking
Event source	MD(Motion Detection), Sensor, Text, Video Loss	SERIAL & I/O	
Event check Schedule	24hrs / 7days	Serial port	1 RS-232C, 2 RS-485
Event action	Buzzer, Relay, E-mail, FTP, Alarm pop-up	Sensor input	16 Dry-contacts
MD area	15 x 10	Relay output	4 Relays
Sensor input	Dry contact (NO or NC selectable)	CONTROLLER	
Text input	POS/ATM support, AVE VSI Pro/Hydra support	Device	Front panel, IR remote, Joystick Keyboard, Mouse
SYSTEM ALARM		SOFTWARE	
Alarm source	HDD fail, HDD almost full, Fan fail, Password fail, WRS fail	Web viewer	Monitoring / Event / PTZ / Playback with IE
Alarm action	Warning message, Buzzer, E-mail, Relay	Java viewer	Monitoring / Event / PTZ with IE, Chrome, Safari
AUDIO		Mobile viewer	Monitoring / PTZ / LogView with iPhone & Android
Input/output	Input 4ch RCA / output HDMI, RCA	CMS	Control Center Standard, Max. 1024 DVRs
Compression	16KHz, 16bit sampling ADPCM	SDK	ActiveX(COM) SDK
Direction	Both	ENVIRONMENTAL & PHYSICAL	
PTZ		Dimension	445(W) x 418(D) x 88(H) mm
Protocols	35 models including C1080, C1080PT-Z20, Pelco-D, Pelco-P, Samsung, Panasonic and others	Weight	10 Kg (No HDD)
		Operating Temperature	5°C~45°C (41°F ~ 113°F)
		Power	AC free volt (100 ~ 240VAC), 50/60Hz
		Power Consumption	Max. 100W Typical 70W(1 HDD)
		Approval	KC, FCC, CE, RoHS, HDcctv(TBD)

HDC1601M

VIDEO INPUT		NETWORK	
Video input standard	SMPTE 292M (HD-SDI)	Interface	1 Gigabit Ethernet (10/100/1000Mbps)
Resolution / Frame Rate	SMPTE 274M(1080p, 1920x1080) : 25, 30, 29.97 fps Input format auto detection	Type	Static IP, Dynamic IP, xDSL
Connectors	16ch, 75Ω BNC connector	DDNS	WNS, DynDNS, NoIP, WRS
VIDEO OUTPUT		Bandwidth limit	Supported
Video output	HDMI	NTP	Server / Client / Both
	1, 4, 9, 10, 13, 16 split-screen	Users	10 monitoring, 2 playback
	User defined sequence / Alarm pop-up	Streaming	1 HD, H.264 stream, Same as recording setting
	1920 x 1080p via HDMI port		1 additional H.264 stream, nHD(640 x 360)
RECORDING		1 JPEG stream, nHD(640 x 360) for e-mail or mobile	
Compression	H.264 / JPEG	SECURITY	
Resolution	1920 x 1080	User level	1 admin, 10 users
Rate	100fps/120fps at 1080p	User privilege	Menu, PTZ, Relay, Playback, Power, Copy, Network MIC
Quality	1080p, 10 levels up to 12Mbps	IP filtering	Supported
Mode	Time, Calendar, Timeline, Event, Thumbnail, Smart, Text	STORAGE & BACKUP	
Schedule	24hrs / 7days	Storage devices	2 internal SATA HDDs, , 1 external eSATA Interface
PLAYBACK		File system	Proprietary file system, Data-loss protection against power-failure
Mode	Instant playback / search	Capacity	Max. 16TB with eSATA
Speed	Max. 100fps/120fps at 1080p	Backup type	Multi-channel or Single channel avi file
Search type	Time, Calendar, Event, Thumbnail, Smart, Text	Backup device	USB drive (2 ports)
Block playback	24hours ~ 99days	S.M.A.R.T.	Temperature and Health checking
EVENT & ALARM		SEIRAL & I/O	
Event source	MD(Motion Detection), Sensor, Text, Video Loss	Serial port	1 RS-232C, 2 RS-485
Event check schedule	24hrs / 7days	Sensor input	16 Dry-contacts
Event action	Buzzer, Relay, E-mail, FTP, Alarm pop-up	Relay output	2 Relays
MD area	15 x 10	CONTROLLER	
Sensor input	Dry contact (NO or NC selectable)	Device	Front panel, IR remote, Joystick Keyboard, Mouse
Text input	POS/ATM support, AVE VSI Pro/Hydra support	SOFTWARE	
SYSTEM ALARM		Web viewer	Monitoring / Event / PTZ / Playback with IE
Alarm source	HDD fail, HDD almost full, Password fail, WRS fail	Java viewer	Monitoring / Event/ PTZ with IE, Chrome, Safari
Alarm action	Warning message, Buzzer, E-mail, Relay	Mobile viewer	Monitoring / PTZ /LogView with iPhone & Android
AUDIO		CMS	Control Center Standard, Max. 1024 DVRs
Input/output	Input 4ch RCA / output HDMI, RCA	SDK	ActiveX(COM) SDK
Compression	16KHz, 16bit sampling ADPCM	ENVIRONMENTAL & PHYSICAL	
Direction	Both	Dimension	350(W) x 393(D) x 88(H) mm
PTZ		Weight	8 Kg (No HDD)
Protocols	35 models including C1080, C1080PT-Z20, Pelco-D, Pelco-P, Samsung, Panasonic and others	Operating Temperature	5°C~45°C (41°F ~ 113°F)
		Power	AC free volt (100 ~ 240VAC), 50/60Hz
		Power consumption	Max. 40W Typical 30W
		Approval	KC, FCC, CE, RoHS, HDcctv(TBD)

HDC801F-PD

VIDEO INPUT		NETWORK	
Video input standard	SMPTE 292M (HD-SDI) DoubleReach™ support for 4 channels	Interface	1 Gigabit Ethernet (10/100/1000Mbps)
Resolution / Framerate	SMPTE 274M(1080p, 1920x1080) : 25, 30, 29.97 fps Input format auto detection	Type	Static IP, Dynamic IP, xDSL
Connectors	8ch, 75Ω BNC connector	DDNS	WNS, DynDNS, NoIP, WRS
PoC	8ch, Power over Coax, Max. 16 W/ch, Total 120W	Bandwidth limit	Supported
CoC	8ch, Control over Coax, Max. 57,600bps	NTP	Server / Client / Both
VIDEO OUTPUT		Users	10 monitoring, 2 playback
Video output	HDMI	Streaming	1 HD, H.264 stream, Same as recording setting
	1, 4, 8 split-screen		1 additional H.264 stream, nHD(640 x 360)
	User defined sequence / Alarm pop-up 1920 x 1080p via HDMI port		1 JPEG stream, nHD(640 x 360) for e-mail or mobile
RECORDING		SECURITY	
Compression	H.264 / JPEG	User level	1 admin, 10 users
Resolution	1920 x 1080	User privilege	Menu, PTZ, Relay, Playback, Power, Copy, Network MIC
Rate	200fps/240fps at 1080p	IP filtering	Supported
Quality	1080p, 10 levels up to 12Mbps	STORAGE & BACKUP	
Mode	Manual & Event / Schedule & Event / Continuous & Event	Storage devices	2 internal SATA HDDs, 1 external eSATA Interface
Schedule	24hrs / 7days	File system	Proprietary file system, Data-loss protection against power-failure
PLAYBACK		Capacity	Max. 16TB with eSATA
Mode	Instant playback / search	Backup type	Multi-channel or Single channel avi file
Speed	Max. 200fps/240fps at 1080p	Backup device	USB drive (2 ports)
Search type	Time, Calendar, Timeline, Event, Thumbnail, Smart, Text	S.M.A.R.T.	Temperature and Health checking
Block playback	24hours ~ 99days	SEIRAL & I/O	
EVENT & ALARM		Serial port	1 RS-232C, 2 RS-485
Event source	MD(Motion Detection), Sensor, Text, Video Loss	Sensor input	8 Dry-contacts
Event check schedule	24hrs / 7days	Relay output	2 Relays
Event action	Buzzer, Relay, E-mail, FTP, Alarm pop-up	CONTROLLER	
MD area	15 x 10	Device	Front panel, IR remote, Joystick Keyboard, Mouse
Sensor input	Dry contact (NO or NC selectable)	SOFTWARE	
Text input	POS/ATM support, AVE VSI Pro/Hydra support	Web viewer	Monitoring / Event / PTZ / Playback with IE
SYSTEM ALARM		Java viewer	Monitoring / Event/ PTZ with IE, Chrome, Safari
Alarm source	HDD fail, HDD almost full, Password fail, WRS fail	Mobile viewer	Monitoring / PTZ / LogView with iPhone & Android
Alarm action	Warning message, Buzzer, E-mail, Relay	CMS	Control Center Standard, Max. 1024 DVRs
AUDIO		SDK	ActiveX(COM) SDK
Input/output	Input 4ch RCA / output HDMI, RCA	ENVIRONMENTAL & PHYSICAL	
Compression	16KHz, 16bit sampling ADPCM	Dimension	350(W) x 393(D) x 88(H) mm
Direction	Both	Weight	8 Kg (No HDD)
PTZ		Operating Temperature	5°C~45°C (41°F ~ 113°F)
Protocols	35 models including C1080, C1080PT-Z20, Pelco-D, Pelco-P, Samsung, Panasonic and others	Power	AC free volt (100 ~ 240VAC), 50/60Hz
		PoC Power	DC 24V/5A (Option)
		Power consumption	Max. 40W Typical 30W
		Approval	KC, FCC, CE, RoHS, HDcctv(TBD)

HDC801H

VIDEO INPUT		NETWORK	
Video input standard	SMPTE 292M (HD-SDI)	Interface	1 Gigabit Ethernet (10/100/1000Mbps)
Resolution / Framerate	SMPTE 274M(1080p, 1920x1080) : 25, 30, 29.97 fps Input format auto detection	Type	Static IP, Dynamic IP, xDSL
Connectors	8ch, 75Ω BNC connector	DDNS	WNS, DynDNS, NoIP, WRS
VIDEO OUTPUT		Bandwidth limit	Supported
Video output	HDMI	NTP	Server / Client / Both
	1, 4, 8 split-screen	Users	10 monitoring, 2 playback
	User defined sequence / Alarm pop-up	Streaming	1 HD, H.264 stream, Same as recording setting
	1920 x 1080p via HDMI port		1 additional H.264 stream, nHD(640 x 360)
RECORDING		1 JPEG stream, nHD(640 x 360) for e-mail or mobile	
Compression	H.264 / JPEG	SECURITY	
Resolution	1920 x 1080	User level	1 admin, 10 users
Rate	100fps/120fps at 1080p	User privilege	Menu, PTZ, Relay, Playback, Power, Copy, Network MIC
Quality	1080p, 10 levels up to 12Mbps	IP filtering	Supported
Mode	Manual & Event / Schedule & Event / Continuous & Event	STORAGE & BACKUP	
Schedule	24hrs / 7days	Storage devices	2 internal SATA HDDs, 1 external eSATA Interface
PLAYBACK		File system	Proprietary file system, Data-loss protection against power-failure
Mode	Instant playback / search	Capacity	Max. 16TB with eSATA
Speed	Max. 100fps/120fps at 1080p	Backup type	Multi-channel or Single channel avi file
Search type	Time, Calendar, Timeline, Event, Thumbnail, Smart, Text	Backup device	USB drive (2 ports)
Block playback	24hours ~ 99days	S.M.A.R.T.	Temperature and Health checking
EVENT & ALARM		SEIRAL & I/O	
Event source	MD(Motion Detection), Sensor, Text, Video Loss	Serial port	1 RS-232C, 2 RS-485
Event check schedule	24hrs / 7days	Sensor input	8 Dry-contacts
Event action	Buzzer, Relay, E-mail, FTP, Alarm pop-up	Relay output	2 Relays
MD area	15 x 10	CONTROLLER	
Sensor input	Dry contact (NO or NC selectable)	Device	Front panel, IR remote, Joystick Keyboard, Mouse
Text input	POS/ATM support, AVE VSI Pro/Hydra support	SOFTWARE	
SYSTEM ALARM		Web viewer	Monitoring / Event / PTZ / Playback with IE
Alarm source	HDD fail, HDD almost full, Password fail, WRS fail	Java viewer	Monitoring / Event/ PTZ with IE, Chrome, Safari
Alarm action	Warning message, Buzzer, E-mail, Relay	Mobile viewer	Monitoring / PTZ / LogView with iPhone & Android
AUDIO		CMS	Control Center Standard, Max. 1024 DVRs
Input/output	Input 4ch RCA / output HDMI, RCA	SDK	ActiveX(COM) SDK
Compression	16KHz, 16bit sampling ADPCM	ENVIRONMENTAL & PHYSICAL	
Direction	Both	Dimension	350(W) x 393(D) x 88(H) mm
PTZ		Weight	8 Kg (No HDD)
Protocols	35 models including C1080, C1080PT-Z20, Pelco-D, Pelco-P, Samsung, Panasonic and others	Operating Temperature	5°C~45°C (41°F ~ 113°F)
		Power	AC free volt (100 ~ 240VAC), 50/60Hz
		Power consumption	Max. 40W Typical 30W
		Approval	KC, FCC, CE, RoHS, HDcctv(TBD)

HDC400F-PD

VIDEO INPUT		NETWORK	
Video input standard	SMPTE 292M (HD-SDI) DoubleReach™ support for 2 channels	Interface	1 Gigabit Ethernet (10/100/1000Mbps)
Resolution / Framerate	SMPTE 274M(1080p, 1920x1080) : 25, 30, 29.97 fps Input format auto detection	Type	Static IP, Dynamic IP, xDSL
Connectors	4ch, 75Ω BNC connector	DDNS	WNS, DynDNS, NoIP, WRS
PoC	4ch, Power over Coax, Max. 16 W/ch, Total 64W	Bandwidth limit	Supported
CoC	4ch, Control over Coax, Max. 57,600bps	NTP	Server / Client / Both
VIDEO OUTPUT		Users	10 monitoring, 2 playback
Video output	HDMI	Streaming	1 HD, H.264 stream, Same as recording setting
	1, 4 split-screen		1 additional H.264 stream, nHD(640 x 360)
	User defined sequence / Alarm pop-up		1 JPEG stream, nHD(640 x 360) for e-mail or mobile
	1920 x 1080p via HDMI port	SECURITY	
RECORDING		User level	1 admin, 10 users
Compression	H.264 / JPEG	User privilege	Menu, PTZ, Relay, Playback, Power, Copy, Network MIC
Resolution	1920 x 1080	IP filtering	Supported
Rate	100fps/120fps at 1080p	STORAGE & BACKUP	
Quality	1080p, 10 levels up to 12Mbps	Storage devices	1 internal SATA HDDs, 1 external eSATA Interface
Mode	Manual & Event / Schedule & Event / Continuous & Event	File system	Proprietary file system, Data-loss protection against power-failure
Schedule	24hrs / 7days	Capacity	Max. 16TB with eSATA
PLAYBACK		Backup type	Multi-channel or Single channel avi file
Mode	Instant playback / search	Backup device	USB drive (2 ports)
Speed	Max. 100fps/120fps at 1080p	S.M.A.R.T.	Temperature and Health checking
Search type	Time, Calendar, Timeline, Event, Thumbnail, Smart, Text	SEIRAL & I/O	
Block playback	24hours ~ 99days	Serial port	1 RS-232C, 2 RS-485
EVENT & ALARM		Sensor input	4 Dry-contacts
Event source	MD(Motion Detection), Sensor, Text, Video Loss	Relay output	2 Relays
Event check schedule	24hrs / 7days	CONTROLLER	
Event action	Buzzer, Relay, E-mail, FTP, Alarm pop-up	Device	Front panel, IR remote, Joystick Keyboard, Mouse
MD area	15 x 10	SOFTWARE	
Sensor input	Dry contact (NO or NC selectable)	Web viewer	Monitoring / Event / PTZ / Playback with IE
Text input	POS/ATM support, AVE VSI Pro/Hydra support	Java viewer	Monitoring / Event/ PTZ with IE, Chrome, Safari
SYSTEM ALARM		Mobile viewer	Monitoring with PTZ, iPhone & Android supported
Alarm source	HDD fail, HDD almost full, Password fail, WRS fail	CMS	Control Center Standard, Max. 1024 DVRs
Alarm action	Warning message, Buzzer, E-mail, Relay	SDK	ActiveX(COM) SDK
AUDIO		ENVIRONMENTAL & PHYSICAL	
Input/output	Input 4ch RCA / output HDMI	Dimension	290(W) x 232(D) x 65(H) mm
Compression	16KHz, 16bit sampling ADPCM	Weight	2.5 Kg (No HDD)
Direction	Both	Operating Temperature	5°C~45°C (41°F ~ 113°F)
PTZ		Power	DC24V, 5A
Protocols	35 models including C1080, C1080PT-Z20, Pelco-D, Pelco-P, Samsung, Panasonic and others	Power consumption	Max. 30W Typical 20W
		Approval	KC, FCC, CE, RoHS, HDcctv(TBD)

HDC400F

VIDEO INPUT		NETWORK	
Video input standard	SMPTE 292M (HD-SDI)	Interface	1 Gigabit Ethernet (10/100/1000Mbps)
Resolution / Framerate	SMPTE 274M(1080p, 1920x1080) : 25, 30, 29.97 fps Input format auto detection	Type	Static IP, Dynamic IP, xDSL
Connectors	4ch, 75Ω BNC connector	DDNS	WNS, DynDNS, NoIP, WRS
VIDEO OUTPUT		Bandwidth limit	Supported
Video output	HDMI	NTP	Server / Client / Both
	1, 4 split-screen	Users	10 monitoring, 2 playback
	User defined sequence / Alarm pop-up	Streaming	1 HD, H.264 stream, Same as recording setting
	1920 x 1080p via HDMI port		1 additional H.264 stream, nHD(640 x 360)
RECORDING		SECURITY	
Compression	H.264 / JPEG	User level	1 admin, 10 users
Resolution	1920 x 1080	User privilege	Menu, PTZ, Relay, Playback, Power, Copy, Network MIC
Rate	100fps/120fps at 1080p	IP filtering	Supported
Quality	1080p, 10 levels up to 12Mbps	STORAGE & BACKUP	
Mode	Manual & Event / Schedule & Event / Continuous & Event	Storage devices	2 internal SATA HDDs
Schedule	24hrs / 7days	File system	Proprietary file system, Data-loss protection against power-failure
PLAYBACK		Backup type	Multi-channel or Single channel avi file
Mode	Instant playback / search	Backup device	USB drive (2 ports)
Speed	Max. 100fps/120fps at 1080p	S.M.A.R.T.	Temperature and Health checking
Search type	Time, Calendar, Timeline, Event, Thumbnail, Smart, Text	SEIRAL & I/O	
Block playback	24hours ~ 99days	Serial port	1 RS-232C, 2 RS-485
EVENT & ALARM		Sensor input	4 Dry-contacts
Event source	MD(Motion Detection), Sensor, Text, Video Loss	Relay output	2 Relays
Event check schedule	24hrs / 7days	CONTROLLER	
Event action	Buzzer, Relay, E-mail, FTP, Alarm pop-up	Device	Front panel, IR remote, Joystick Keyboard, Mouse
MD area	15 x 10	SOFTWARE	
Sensor input	Dry contact (NO or NC selectable)	Web viewer	Monitoring / Event / PTZ / Playback with IE
Text input	POS/ATM support, AVE VSI Pro/Hydra support	Java viewer	Monitoring / Event/ PTZ with IE, Chrome, Safari
SYSTEM ALARM		Mobile viewer	Monitoring / PTZ / LogView with iPhone & Android
Alarm source	HDD fail, HDD almost full, Password fail, WRS fail	CMS	Control Center Standard, Max. 1024 DVRs
Alarm action	Warning message, Buzzer, E-mail, Relay	SDK	ActiveX(COM) SDK
AUDIO		ENVIRONMENTAL & PHYSICAL	
Input/output	Input 4ch RCA / output HDMI	Dimension	290(W) x 232(D) x 65(H) mm
Compression	16KHz, 16bit sampling ADPCM	Weight	2.5 Kg (No HDD)
Direction	Both	Operating Temperature	5°C~45°C (41°F ~ 113°F)
PTZ		Power	DC12V, 5A
Protocols	35 models including C1080, C1080PT-Z20, Pelco-D, Pelco-P, Samsung, Panasonic and others	Power consumption	Max. 30W Typical 20W
		Approval	KC, FCC, CE, RoHS, HDcctv(TBD)

Product Dimension

HD1600F-PDR / HD1600F-R *

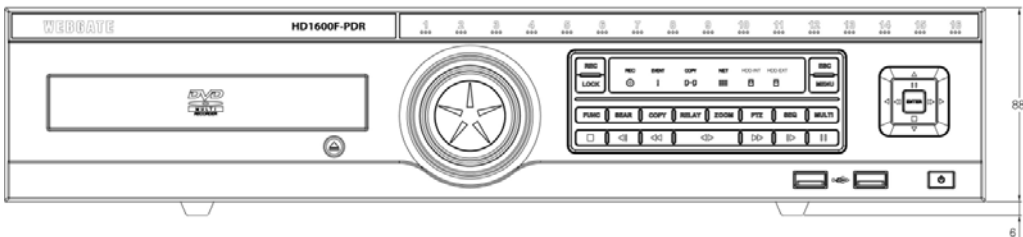
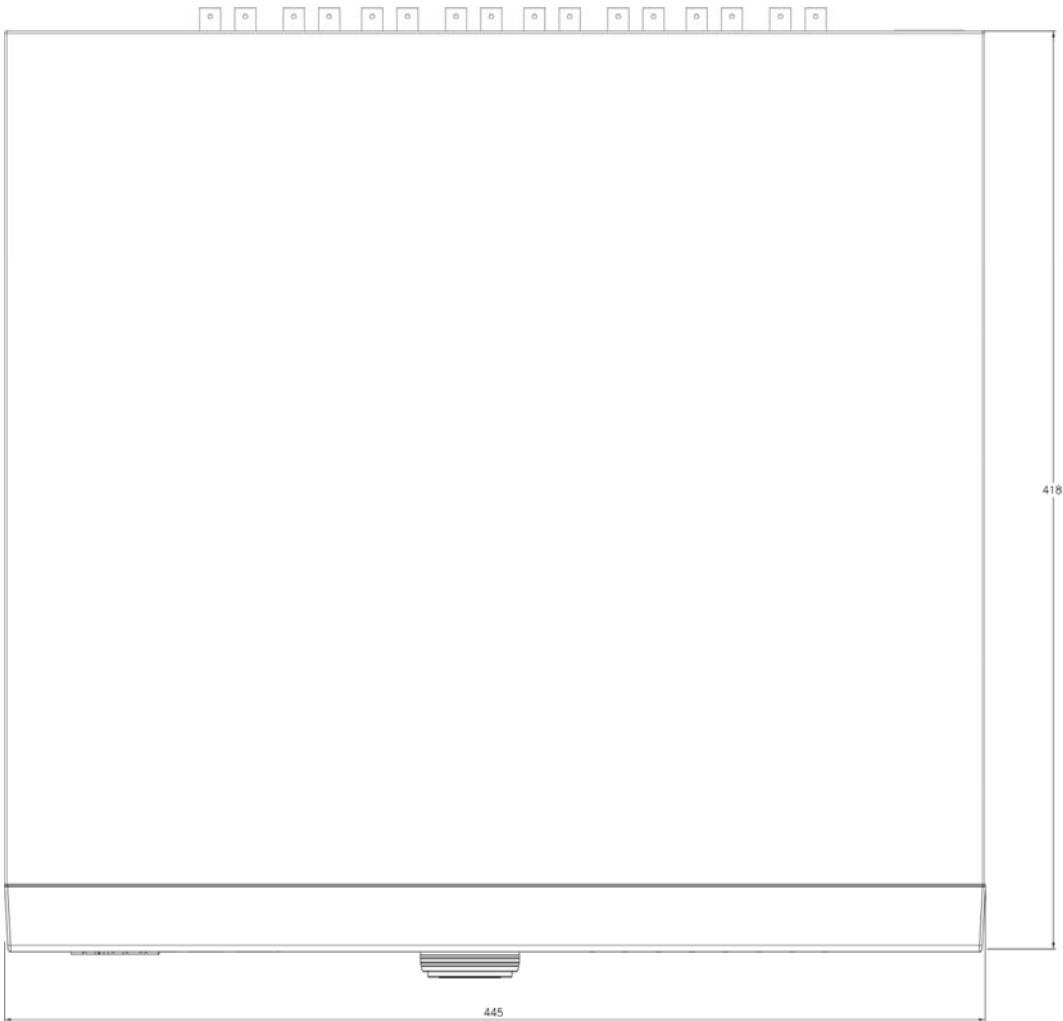
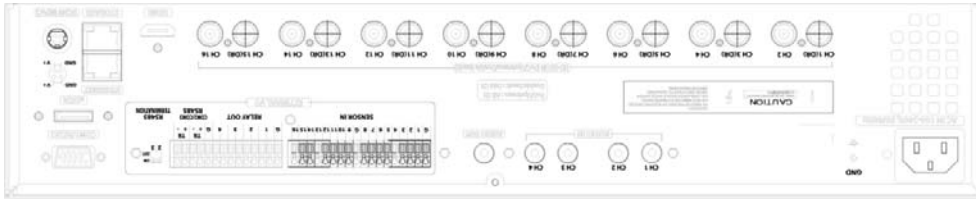

* Varies between different models

HDC400F-PD / HDC400F *

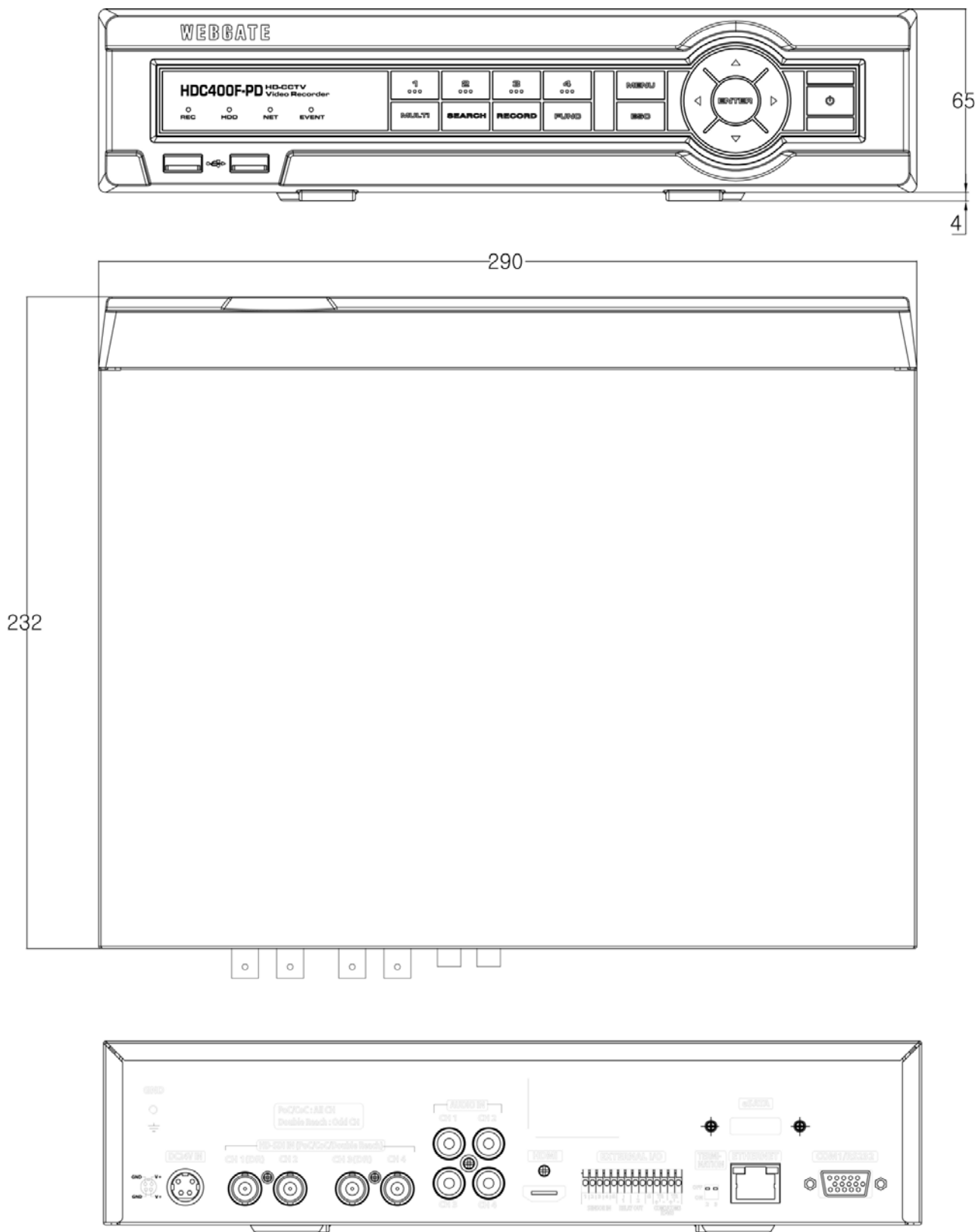

* Varies between different models

Open Source License Report on the Product

The software included in this product contains copyrighted software that is licensed under the GPL/LGPL. You may obtain the complete Corresponding Source code from us for a period of three years after our last shipment of this product by sending email to <rmcvt@gmail.com>.

If you want to obtain the complete Corresponding Source code in the physical medium such as CD-ROM, the cost of physically performing source distribution might be charged.

GPL Software : busybox, boa, CySSL, dosfstools, linux kernel, rp-ppoe, cdrtools, dvd-rw-tools, dhcpcd, iproute2, smartmontools

LGPL/GPL with exceptions : glibc, libgcc, libstdc++, FFMpeg, Ftplib

Apache License : ash, minipnpic, telnet-server, YUI Library, ppp

Copyright (c) 2007, Google Corp.; Copyright (c) 2008,2009 WenQuanYi Board of Trustees and Qianqian Fang.

Apache License : Apache Commons

http://commons.apache.org

BSD License : ash, minipnpic, telnet-server, YUI Library, ppp

Freetype License : freetype2

Portions of this software included in this product are copyright (C) 2010 The FreeType Project (www.freetype.org). All rights reserved.

JG License : JPEG

The software included in this product is based in part on the work of the Independent JPEG Group.

MIT License : c-ares, curl, libaouth, jcodec

OpenSSL License : OpenSSL

SIL Open Font License : Arimo

Copyright (c) 2010 Google Corporation.

This Font Software is licensed under the SIL Open Font License, Version 1.1.

This license is copied in this manual, and is also available with a FAQ at: <http://scripts.sil.org/OFL>

GNU GENERAL PUBLIC LICENSE

Version 2, June 1989

Copyright (C) 1989, 1991 Free Software Foundation, Inc.

51 Franklin Street, Fifth Floor, Boston, MA 02110-1301, USA

Everyone is permitted to copy and distribute verbatim copies of this license document, but changing it is not allowed.

Preamble

The licenses for most software are designed to take away your freedom to share and change it. By contrast, the GNU General Public License is intended to guarantee your freedom to share and change free software—to make sure the software is free for all its users. This General Public License applies to most of the Free Software Foundation's software and to any other program whose authors commit to using it. (Some other Free Software Foundation software is covered by the GNU Lesser General Public License instead.) You can apply it to your programs, too.

When we speak of free software, we are referring to freedom, not price. Our General Public Licenses are designed to make sure that you have the freedom to distribute copies of free software (and charge for this service if you wish), that you receive source code or can get it if you want it, that you can change the software or use pieces of it in new free programs; and that you know you can do these things.

To protect your rights, we need to make restrictions that forbid anyone to deny you these rights or to ask you to surrender the rights. These restrictions translate to certain responsibilities for you if you distribute copies of the software, or if you modify it.

For example, if you distribute copies of such a program, whether gratis or for a fee, you must give the recipients all the rights that you have. You must make sure that they, too, receive or can get the source code. And you must show them these terms so they know their rights.

We protect your rights with two steps: (1) copyright the software, and (2) offer you this license which gives you legal permission to copy, distribute and/or modify the software.

Also, for each author's protection and ours, we want to make certain that everyone understands that there is no warranty for this free software. If the software is modified by someone else and passed on, we want its recipients to know that what they have is not the original, so that any problems introduced by others will not reflect on the original authors' reputations.

Finally, any free program is threatened constantly by software patents. We wish to avoid the danger that redistributors of a free program will individually obtain patent licenses, in effect making the program proprietary. To prevent this, we have made it clear that any patent must be licensed for everyone's free use or not licensed at all.

The precise terms and conditions for copying, distribution and modification follow.

TERMS AND CONDITIONS FOR COPYING, DISTRIBUTION AND MODIFICATION

0. This License applies to any program or other work which contains a notice placed by the copyright holder saying it may be distributed under the terms of this General Public License. The "Program", below, refers to any such program or work, and a "work based on the Program" means either the Program or any derivative work under copyright law; that is to say, a work containing the Program or a portion of it, either verbatim or with additions and/or deletions; or translated into another language. (Hereinafter, translation is included without limitation in the term "modification".) Each licensee is addressed as "you".

Activities other than copying, distribution and modification are not covered by this License; they are outside its scope. The act of running the Program is not restricted, and the output from the Program is covered only if its contents, considered as a work based on the Program (independent of having been made by running the Program). Whether that is true depends on what the Program does.

1. You may copy and distribute verbatim copies of the Program's source code as you receive it, in any medium, provided that you conspicuously and appropriately publish on each copy an appropriate copyright notice and disclaimer of warranty, keep intact all the notices that refer to this License and to the absence of any warranty, and give any other recipients of the Program a copy of this License along with the Program.

You may charge a fee for the physical act of transferring a copy, and you may at your option offer warranty protection in exchange for a fee.

2. You may modify your copy or copies of the Program or any portion of it, thus forming a work based on the Program, and copy and distribute such modifications or work under the terms of Section 1 above, provided that you also meet all of these conditions:

a) You must cause the modified files to carry prominent notices stating that you changed the files and the date of any change.

b) You must cause any work that you distribute or publish, that in whole or in part contains or is derived from the Program or any part thereof, to be licensed as a whole at no charge to all third parties under the terms of this License.

c) If the modified program normally reads commands interactively when run, you must cause it, when started running for such interactive use in the most ordinary way, to print or display an announcement including an appropriate copyright notice and a notice that there is no warranty (or else, saying that you provide a warranty) and that users may redistribute the program under these conditions, and telling the user how to view a copy of this License. (Exception: if the Program itself is interactive but does not normally print such an announcement, your work based on the Program is not required to print an announcement.)

These requirements apply to the modified work as a whole. If identifiable sections of that work are not derived from the Program, and can be reasonably considered independent and separate works in themselves, then this License, and its terms, do not apply to those sections when you distribute them as separate works. But when you distribute the same sections as part of a whole which is a work based on the Program, the distribution of the whole must be on the terms of this License, with the exception that other licensees extend to the entire whole, and thus to each and every part regardless of who wrote it. Thus, if it is not the intent of this section to claim rights or contest your rights to work written entirely by you; rather, the intent is to exercise the right to control the distribution of derivative or collective works based on the Program.

In addition, mere aggregation of another work not based on the Program with the Program (or with a work based on the Program) on a volume of a storage or distribution medium does not bring the other work under the scope of this License.

3. You may copy and distribute the Program (or a work based on it, under Section 2) in object code or executable form under the terms of Sections 1 and 2 above provided that you also do one of the following:

a) Accompany it with the complete corresponding machine-readable source code, which must be distributed under the terms of Sections 1 and 2 above on a medium customarily used for software interchange; or,

b) Accompany it with a written offer, valid for at least three years, to give any third party, for a charge no more than your cost of physically performing source distribution, a complete machine-readable copy of the corresponding source code, to be distributed under the terms of Sections 1 and 2 above on a medium customarily used for software interchange; or,

c) Accompany it with the information you received as to the offer to distribute corresponding source code. (This alternative is allowed only for noncommercial distribution and only if you received the program in object code or executable form with such an offer, in accord with Subsection b) above.)

The source code for a work means the preferred form of the work for making modifications to it. For an executable work, complete source code means all the source code for all modules it contains, plus any associated interface definition files, scripts used to control compilation and installation of the executable. However, as a special exception, the source code distributed need not include anything that is normally distributed (in either source or binary form) with the major components (compiler, kernel, and so on) of the operating system on which the executable runs, unless that component itself accompanies the executable.

If distribution of executable or object code is made by offering access to copy from a designated place, then offering equivalent access to copy the source code from the same place counts as distribution of the source code, even though third parties are not compelled to copy the source along with the object code.

4. You may not copy, modify, sublicense, or distribute the Program except as expressly provided under this License. Any attempt otherwise to copy, modify, sublicense or distribute the Program is void, and will automatically terminate your rights under this License. However, parties who have received copies, or rights, from you under this License will not have their licenses terminated so long as they remain in full compliance.

5. You are not required to accept this License, since you have not signed it. However, nothing else grants you permission to copy or distribute the Program or its derivative works. These actions are prohibited by law if you do not accept this License. Therefore, by modifying or distributing the Program (or any work based on the Program), you indicate your acceptance of this License to do so, and all its terms and conditions for copying, distributing or modifying the Program or works based on it.

6. Each time you redistribute the Program (or any work based on the Program), the recipient automatically receives a license in the same form as the license you received to copy, distribute or modify the Program under these terms and conditions. You may not impose any further restrictions on the recipients' exercise of the rights granted herein. You are not responsible for enforcing compliance by third parties to this License.

7. If as a consequence of a court judgment or allegation of patent infringement or for any other reason (not limited to patent issues), conditions are imposed on you (whether by court order, agreement or otherwise) that contradict the conditions of this License, they do not excuse you from the conditions of this License. If you cannot distribute so as to satisfy simultaneously your obligations under this License and any other pertinent obligations, then as a consequence you may not distribute the Program at all. For example, if a patent license would not permit royalty-free redistribution of the Program by all those who receive copies directly or indirectly through you, then the only way you could satisfy both it and this License would be to refrain entirely from distribution of the Program.

If any portion of this section is held invalid or unenforceable under any particular circumstance, the balance of the section is intended to apply and the section as a whole is intended to apply in other circumstances.

It is not the purpose of this section to induce you to infringe any patents or other property right claims or to contest validity of any such claims; this section has the sole purpose of protecting the integrity of the free software distribution system, which is implemented by public license practices. Many people have made generous contributions to the wider variety of software distributed through that system in reliance on consistent application of that system; it is up to the author/donor to decide if he or she is willing to distribute software through any other system and a licensee cannot impose that choice.

This section is intended to make thoroughly clear what is believed to be a consequence of the rest of this License.

8. If the distribution and/or use of the Program is restricted in certain countries either by patents or by copyrighted interfaces, the original copyright holder who places the Program under this License may add an explicit geographical distribution limitation excluding those countries, so that distribution is permitted only in or among countries not thus excluded. In such case, this License incorporates the limitation as if it were in the body of this License.

9. The Free Software Foundation may publish revised and/or new versions of the General Public License from time to time. Such new versions will be similar in spirit to the present version, but may differ in detail to address new problems or concerns.

Each version is given a distinguishing version number. If the Program specifies a version number of this License which applies to it and "any later version", you have the option of following the terms and conditions either of that version or of any later version published by the Free Software Foundation. If the Program does not specify a version number of this License, you may choose any version ever published by the Free Software Foundation.

10. If you wish to incorporate parts of the Program into other free programs whose distribution conditions are different, write to the author to ask for permission. For software which is copyrighted by the Free Software Foundation, write to the Free Software Foundation; we sometimes make exceptions for this. Our decision will be guided by the two goals of preserving the free status of all derivatives of our free software and of promoting the sharing and reuse of software generally.

NO WARRANTY

11. BECAUSE THE PROGRAM IS LICENSED FREE OF CHARGE, THERE IS NO WARRANTY FOR THE PROGRAM, TO THE EXTENT PERMITTED BY APPLICABLE LAW. EXCEPT WHEN OTHERWISE STATED IN WRITING THE COPYRIGHT HOLDERS AND/OR OTHER PARTIES PROVIDE THE PROGRAM "AS IS" WITHOUT WARRANTY OF ANY KIND, EITHER EXPRESSED OR IMPLIED, INCLUDING, BUT NOT LIMITED TO, THE IMPLIED WARRANTIES OF MERCHANTABILITY AND FITNESS FOR A PARTICULAR PURPOSE. THE ENTIRE RISK AS TO THE QUALITY AND PERFORMANCE OF THE PROGRAM IS WITH YOU. SHOULD THE PROGRAM PROVE DEFECTIVE, YOU ASSUME THE COST OF ALL NECESSARY SERVICING, REPAIR OR CORRECTION.

12. IN NO EVENT UNLESS REQUIRED BY APPLICABLE LAW OR AGREED TO IN WRITING WILL ANY COPYRIGHT HOLDER, OR ANY OTHER PARTY WHO MAY MODIFY AND/OR REDISTRIBUTE THE PROGRAM AS PERMITTED ABOVE, BE LIABLE TO YOU FOR DAMAGES, INCLUDING ANY GENERAL, SPECIAL, INCIDENTAL OR CONSEQUENTIAL DAMAGES ARISING OUT OF THE USE OR INABILITY TO USE THE PROGRAM (INCLUDING BUT NOT LIMITED TO LOSS OF DATA OR DATA BEING RENDERED INACCURATE OR LOSSES SUSTAINED BY YOU OR THIRD PARTIES OR A FAILURE OF THE PROGRAM TO OPERATE WITH ANY OTHER PROGRAMS), EVEN IF SUCH HOLDER OR OTHER PARTY HAS BEEN ADVISED OF THE POSSIBILITY OF SUCH DAMAGES.

END OF TERMS AND CONDITIONS

How to Apply These Terms to Your New Programs

If you develop a new program, and you want it to be of the greatest possible use to the public, the best way to achieve this is to make it free software which everyone can redistribute and change under these terms.

To do so, attach the following notices to the program. It is safest to attach them to the start of each source file to most effectively convey the exclusion of warranty; and each file should have at least the "copyright" line and a pointer to where the full notice is found.

one line to give the program's name and an idea of what it does.
Copyright (C) yyyy name of author

This program is free software; you can redistribute it and/or modify it under the terms of the GNU General Public License as published by the Free Software Foundation; either version 2 of the License, or (at your option) any later version.

This program is distributed in the hope that it will be useful, but WITHOUT ANY WARRANTY; without even the implied warranty of MERCHANTABILITY or FITNESS FOR A PARTICULAR PURPOSE. See the GNU General Public License for more details.

You should have received a copy of the GNU General Public License along with this program; if not, write to the Free Software Foundation, Inc., 51 Franklin Street, Fifth Floor, Boston, MA 02110-1301, USA.

Also add information on how to contact you by electronic and paper mail.
If the program is interactive, make it output a short notice like this when it starts in an interactive mode:
Gnomovision version 69, Copyright (C) year name of author
Gnomovision comes with ABSOLUTELY NO WARRANTY; for details type 'show w'. This is free software, and you are welcome to redistribute it under certain conditions; type 'show c' for details.

The hypothetical commands 'show w' and 'show c' should show the appropriate parts of the General Public License. Of course, the commands you use may be called something other than 'show w' and 'show c'; they could even be menu items—whatever suits your program.

You should also get your employer (if you work as a programmer) or your school, if any, to sign a "copyright disclaimer" for the program, if necessary. Here is a sample; alter the names:

Yooyodyne, Inc., hereby disclaims all copyright interest in the program 'Gnomovision' (which makes passes at compilers) written by James Hacker.

signature of Ty Coon, 1 April 1989
Ty Coon, President of Vice

This General Public License does not permit incorporating your program into proprietary programs. If your program is a subroutine library you may consider it more useful to permit linking proprietary applications with the library. If this is what you want to do, use the GNU Lesser General Public License instead of this License.

GNU GENERAL PUBLIC LICENSE
Version 3, 29 June 2007

Copyright (C) 2007 Free Software Foundation, Inc. <<http://fsf.org/>>

Everyone is permitted to copy and distribute verbatim copies of this license document, but changing it is not allowed.

Preamble

The GNU General Public License is a free, copyleft license for software and other kinds of works. The licenses for most software and other practical works are designed to take away your freedom to share and change the works. By contrast, the GNU General Public License is intended to guarantee your freedom to share and change all versions of a program—to make sure it remains free software for all its users. We, the Free Software Foundation, use the GNU General Public License for most of our software, and we also use it for any other work released this way by our authors. You can apply it to your programs, too.

When we speak of free software, we are referring to freedom, not price. Our General Public Licenses are designed to make sure that you have the freedom to distribute copies of free software (and charge for them if you wish), that you receive source code or can get it if you want it, that you can change the software or use pieces of it in new free programs, and that you know you can do these things.

To protect your rights, we need to prevent others from denying you these rights or asking you to surrender the rights. Therefore, you have certain responsibilities if you distribute copies of the software, or if you modify it: responsibilities to respect the freedom of others.

For example, if you distribute copies of such a program, whether gratis or for a fee, you must pass on to the recipients all the rights that you received. You must make sure that they, too, receive or can get the source code. And you must show them these terms so they know their rights.

Developers that use the GNU GPL protect your rights with two steps: (1) assert copyright on the software, and (2) offer you this License giving you legal permission to copy, distribute and/or modify it. For the developer's protection, the GPL clearly explains that there is no warranty for this free software. For both users' and authors' sake, the GPL requires that modified versions be marked as changed, so that their problems will not be attributed erroneously to authors of previous versions.

Some devices are designed to deny users access to install or run modified versions of the software inside them, although the manufacturer can do so. This is fundamentally incompatible with the aim of protecting users' freedom to change the software. The systematic pattern of such abuse occurs in the area of products for individuals to use, which is precisely where it is most unacceptable. Therefore, we have designed this version of the GPL to prohibit the practice for those products. If such problems arise substantially in other domains, we stand ready to extend this provision to those domains in future versions of the GPL, as needed to protect the freedom of users.

Finally, every program is threatened constantly by software patents. States should not allow patents to restrict development and use of software on general-purpose computers, but in those that do, we wish to avoid the special danger that patents applied to a free program could make it effectively proprietary. To prevent this, the GPL assures that patents cannot be used to render the program non-free.

The precise terms and conditions for copying, distribution and modification follow.

TERMS AND CONDITIONS

0. Definitions.

"This License" refers to version 3 of the GNU General Public License.

"Copyright" also means copyright-like laws that apply to other kinds of works, such as semiconductor masks.

"The Program" refers to any copyrightable work licensed under this License. Each licensee is addressed as "you". "Licensees" and "recipients" may be individuals or organizations.

To "modify" a work means to copy from or adapt all or part of the work in a fashion requiring copyright permission, other than the making of an exact copy. The resulting work is called a "modified version" of the earlier work or a work "based on" the earlier work.

A "covered work" means either the unmodified Program or a work based on the Program. To "propagate" a work means to do anything with it that, without permission, would make you directly or secondarily liable for infringement under applicable copyright law, except executing it on a computer or modifying a private copy. Propagation includes copying, distribution (with or without modification), making available to the public, and in some countries other activities as well. To "convey" a work means any kind of propagation that enables other parties to make or receive copies. Mere interaction with a user through a computer network, with no transfer of a copy, is not conveying. An interactive user interface displays "Appropriate Legal Notices" to the extent that it includes a convenient and prominently visible feature that (1) displays an appropriate copyright notice, and (2) tells the user that there is no warranty for the work (except to the extent that warranties are provided), that licensees may convey the work under this License, and how to view a copy of this License. If the interface presents a list of user commands or options, such as a menu, a prominent item in the list meets this criterion.

1. Source Code
The "source code" for a work means the preferred form of the work for making modifications to it. "Object code" means any non-source form of a work.
A "Standard Interface" means an interface that either is an official standard defined by a recognized standards body or, in the case of interfaces specified for a particular programming language, one that is widely used among developers working in that language.
The "System Libraries" of an executable work include anything, other than the work as a whole, that (a) is included in the normal form of packaging a Major Component, but which is not part of that Major Component, and (b) serves only to enable use of the work with that Major Component, or to implement a Standard Interface for which an implementation is available to the public in source code form. A "Major Component", in this context, means a major essential component (kernel and window system, and one or more of the specific operating system (if any) on which the executable work runs, or a compiler used to produce the work, or an object code interpreter used to run it.

The "Corresponding Source" for a work in object code form means all the source code needed to generate, install, and (for an executable work) run the object code and to modify the work, including scripts to control those activities, however, it does not include the work's System Libraries, or general-purpose tools or generally available free programs which are used unmodified in performing those activities but which are not part of the work. For example, Corresponding Source includes interface definition files associated with source files for the work, and the source code for shared libraries and dynamically linked subprograms of the executable (and the intermediate object files if available) that is used to produce or control the work's execution and other parts of the work. The Corresponding Source need not include anything that users can regenerate automatically from other parts of the Corresponding Source.

The Corresponding Source for a work in source code form is that same work.

2. Basic Permissions.

All rights granted under this License are granted for the term of copyright on the Program, and are irrevocable provided the stated conditions are met. This License explicitly affirms your unlimited permission to run the unmodified Program. The output from running a covered work is covered by this License only if the output, given its content, constitutes a covered work. This License acknowledges your rights of fair use or other equivalent, as provided by copyright law. You may make, run and propagate covered works that you do not convey, without conditions so long as your license otherwise remains in force. You may convey covered works to others for the sole purpose of having them make modifications exclusively for you, or provide you with facilities for running those works, provided that you agree in writing with the copyright holder to extend this limited warranty to you, or to control copyright. Those thus making or running the covered works for you must do so exclusively on your behalf, under your direction and control, on terms that prohibit them from making any copies of your copyrighted material outside their relationship with you.

Conveying under any other circumstances is permitted solely under the conditions stated below.

Sublicensing is permitted under section 10.

3. Protecting Users' Legal Rights From Anti-Circumvention Law.

No covered work shall be deemed part of an effective technological measure under any applicable law fulfilling obligations under article 11 of the WIPO copyright treaty adopted on 20 December 1996, or similar laws prohibiting or restricting circumvention of such measures. When you convey a covered work, you may use legal power to forbid circumvention of technological measures to the extent such circumvention is effected by exercising rights under this License with respect to the covered work, and you disclaim any intention to limit operation or modification of the work as a means of enforcing, against the work's users, your or third parties' legal rights to forbid circumvention of technological measures.

4. Conveying Verbatim Copies.

You may convey verbatim copies of the Program's source code as you receive it, in any medium, provided that you conspicuously and appropriately publish on each copy an appropriate copyright notice; keep intact all notices stating that this License and any non-permissive terms added in accord with section 7 apply to the code as it appears, and you disclaim any warranty, and give all recipients a copy of this License along with the Program. You may charge any price or no price for each copy that you convey, and you may offer support or warranty protection for a fee.

5. Conveying Modified Source Versions.

You may convey a work based on the Program, or the modifications to produce it from the Program, in the form of source code under the terms of section 4, provided that you also meet all of these conditions:

- The work must carry prominent notices stating that you modified it, and giving a relevant date.
- The work must carry prominent notices stating that it is released under this License and any conditions added under section 7. This requirement remains in force if you have received this License from a party who is permitted to use it to "keep intact all notices".
- You must license the entire work, as a whole, under this License to anyone who comes into possession of a copy. This License will therefore apply, along with any applicable section 7 additional terms, to the whole of the work, and all its parts, regardless of how they are packaged. This License gives no permission to license the work in any other way, but it does not invalidate such permission if you have separately received it.
- If the work has interactive user interfaces, each must display Appropriate Legal Notices; however, if the Program has interactive interfaces that do not display Appropriate Legal Notices, your work need not make them do so.

A compilation of a covered work with other separate and independent works, which are not by their nature extensions of the covered work, and which are not combined with it such as to form a larger program, in or on a volume of a storage or distribution medium, is called an "aggregate" if the compilation and its resulting copyright are not used to limit the access or legal rights of the compilation's users beyond what the individual works permit. Inclusion of a covered work in an aggregate does not cause this License to apply to the other parts of the aggregate.

6. Conveying Non-Source Forms.

You may convey a covered work in object code form under the terms of sections 4 and 5, provided that you also convey the machine-readable Corresponding Source under the terms of this License, in one of these ways:

- The object code, in or embodied in, a physical product (including a physical distribution medium), accompanied by the Corresponding Source fixed on a durable physical medium customarily used for software interchange.
- Convey the object code, in or embodied in, a physical product (including a physical distribution medium), accompanied by a printed copy of the Corresponding Source as long as you offer spare parts or customer support for that product model, to give anyone who possesses the object code either (1) a copy of the Corresponding Source for all the software in the product that is covered by this License, on a durable physical medium customarily used for software interchange, for a price no more than your reasonable cost of physically performing this conveying of source, or (2) access to copy the Corresponding Source from a network server at no charge.
- Convey individual copies of the object code with a copy of the written offer to provide the Corresponding Source. This alternative is allowed only occasionally and noncommercially, and only if you received the object code with such an offer, in accord with subsection 6b.
- Convey the object code by offering access from a designated place (gratis or for a charge), and offer equivalent access to the Corresponding Source in the same way through the same place at no further charge. You need not require recipients to copy the Corresponding Source along with the object code. If the place to copy the object code is a network server, the Corresponding Source may be on a different server (operated by you or a third party) that supports equivalent copying facilities, provided you maintain clear directions next to the object code saying where to find the Corresponding Source. Regardless of what server hosts the Corresponding Source, you remain obligated to ensure that it is available for as long as needed to satisfy these requirements.
- Convey the object code using peer-to-peer transmission, provided you inform other peers where the object code and Corresponding Source of the work are being offered to the general public at no charge under subsection 6b.

A separable portion of the object code, whose source code is excluded from the Corresponding Source as a System Library, need not be included in conveying the object code work.

"A User Product" is either (1) a "consumer product", which means any tangible personal property which is normally used for personal, family, or household purposes, or (2) any other kind of personal property which is incorporated into a dwelling. In determining whether a product is a consumer product, doubtful cases shall be resolved in favor of coverage. For a particular product received by a particular user, "normally used" refers to a typical or common use of that class of product, regardless of the status of the particular user or of the way in which the particular user actually uses, or expects to use, the product. A product is a consumer product regardless of whether the product has substantial commercial, industrial or non-consumer uses, unless such uses represent the only significant mode of use of the product. "Installation Information" for a User Product means any methods, procedures, authorization keys, or other information required to install and execute modified versions of a covered work in that User Product from a modified version of the Corresponding Source. The information must suffice to ensure that the continued functioning of the modified object code is in no case prevented or interfered with solely because modification has been made.

If you convey an object code work under this section in, or with, or specifically for use in, a User Product, and the conveying occurs as part of a transaction in which the right of possession and use of the User Product is transferred to the recipient in perpetuity or for a fixed term (regardless of how the transaction is characterized), the Corresponding Source conveyed under this section must be accompanied by the Installation Information. But this requirement does not apply if neither you nor any third party retains the ability to install modified object code on the User Product (for example, the work has been installed in ROM).

The requirement to provide Installation Information does not include a requirement to continue to provide support service, warranty, or updates for a work that has been modified or installed by the recipient, or for the User Product in which it has been modified or installed. Access to a network may be denied when the modification itself materially and adversely affects the operation of the network or violates the rules and protocols for communication across the network.

Corresponding Source conveyed, and Installation Information provided, in accord with this section must

be in a format that is publicly documented (and with an implementation available to the public in source code form), and must require no special password or key for unpacking, reading or copying.

7. Additional Terms.

"Additional permissions" are terms that supplement the terms of this License by making exceptions from one or more of its conditions. Additional permissions that are applicable to the entire Program shall be indicated by their placement into the LICENSE file in this License, to the extent that they are valid under applicable law. If additional permissions apply only to part of the Program, that part may be used separately under those permissions, but the entire Program remains governed by this License without regard to the additional permissions.

You may convey a copy of a covered work, you may at your option remove any additional permissions from that copy, or from any part of it. (Additional permissions may be written to require their own removal in certain cases when you modify the work.) You may place additional permissions on material, added by you to a covered work, for which you have or can give appropriate copyright permission. Notwithstanding any other provision of this License, for material you add to a covered work, you may (if authorized by the copyright holder of that material) supplement the terms of this License with terms:

- Disclaiming warranty or limiting liability differently from the terms of sections 15 and 16 of this License; or
- Requiring preservation of specified reasonable legal notices or author attributions in that material or in the Appropriate Legal Notices displayed by works containing it; or
- Prohibiting misrepresentation of the origin of that material, or requiring that modified versions of such material be marked in reasonable ways as different from the original version; or
- Limiting the use for publicity purposes of names of licensors or authors of the material; or
- Declining to grant rights under trademark law for use of some trade names, trademarks, or service marks; or
- Requiring indemnification of licensors and authors of that material by anyone who conveys the material (or modified versions of it) with contractual assumptions of liability to the recipient, for any liability that these contractual assumptions directly impose on those licensors and authors.

All other non-permissive additional terms are considered "further restrictions" within the meaning of the License (including any patents or licenses granted under the third paragraph of section 11). However, if you place no additional restrictions on the material, then your license from a particular copyright holder is reinstated (a) provisionally, unless and until the copyright holder explicitly and finally terminates your license, and (b) permanently, if the copyright holder fails to notify you of the violation by some reasonable means prior to 60 days after the cessation. Termination of your rights under this section does not terminate the licenses of parties who have received copies of the material from you under this License, or your rights from a particular copyright holder if you have received notice of violation of this License (for any work) from that copyright holder, and you cure the violation prior to 30 days after your receipt of the notice.

Termination of your rights under this section does not terminate the licenses of parties who have received copies of the material from you under this License, or your rights from a particular copyright holder if you have received notice of violation of this License (for any work) from that copyright holder, and you cure the violation prior to 30 days after your receipt of the notice.

8. Termination.

You may not propagate or modify a covered work except as expressly provided under this License. Any attempt otherwise to propagate or modify it is void, and will automatically terminate your rights under this License (including any patents or licenses granted under the third paragraph of section 11). However, if you cease all violation of this License, then your license from a particular copyright holder is reinstated (a) provisionally, unless and until the copyright holder explicitly and finally terminates your license, and (b) permanently, if the copyright holder fails to notify you of the violation by some reasonable means prior to 60 days after the cessation.

Termination of your rights under this section does not terminate the licenses of parties who have received copies of the material from you under this License, or your rights from a particular copyright holder if you have received notice of violation of this License (for any work) from that copyright holder, and you cure the violation prior to 30 days after your receipt of the notice.

Termination of your rights under this section does not terminate the licenses of parties who have received copies of the material from you under this License, or your rights from a particular copyright holder if you have received notice of violation of this License (for any work) from that copyright holder, and you cure the violation prior to 30 days after your receipt of the notice.

9. Acceptance Not Required for Having Copies.

You are not required to accept this License in order to receive or run a copy of the Program. Ancillary propagation of a covered work occurring solely as a consequence of using peer-to-peer transmission to receive a copy likewise does not require acceptance. However, nothing other than this License grants you permission to propagate or modify any covered work. These actions infringe copyright if you do not accept this License. Therefore, by modifying or propagating a covered work, you indicate your acceptance of this License to do so.

10. Automatic Licensing of Downstream Recipients.

Each time you convey a covered work, the recipient automatically receives a license from the original licensor to run, modify and propagate that work, subject to this License. You are not responsible for enforcing compliance by third parties with this License.

An "entity transaction" is a transaction transferring control of an organization, or substantially all assets of an organization, or subdividing an organization, or propagating an organization, if the transaction results from an entity transaction, each party to that transaction who receives a copy of the work also receives whatever licenses to the work the party's predecessor in interest had or could give under the previous paragraph, plus a right to possession of the Corresponding Source of the work from the predecessor in interest, if the predecessor has it or can get it with reasonable efforts. You may not impose any further restrictions on the exercise of the rights granted or affirmed under this License. For example, you may not impose a license fee, royalty, or other charge for exercise of rights granted under this License, and you may not initiate litigation (including a cross-claim or counterclaim in a lawsuit) alleging that any patent claim is infringed by making, using, selling, offering for sale, or importing into the United States any portion of it.

11. Patents.

A "contributor" is a copyright holder who authorizes use under this License of the Program or a work on which the Program is based. The holder thus licensed is called the contributor's "contributor version". A contributor's "essential patent claims" are all patent claims owned or controlled by the contributor, whether already acquired or hereafter acquired, that would be infringed by some combination of the work, of making, using, or selling its contributor version, but do not include claims that would be infringed only as a consequence of further modification of the contributor version. For purposes of this definition, "control" includes the right to grant patent sublicenses in a manner consistent with the requirements of the License. Each contributor grants you a non-exclusive, worldwide, royalty-free patent license under the contributor's essential patent claims, to make, use, sell, offer for sale, import and otherwise run, modify and propagate the contents of its contributor version.

In the following three paragraphs, a "patent license" is any express agreement or commitment, however defined, that not to enforce a patent (such as an express permission to practice a patent or covenant not to sue for patent infringement). To "grant" such a patent license to a party means to make such an agreement or commitment not to enforce a patent against the party.

If you convey a covered work, knowingly relying on a patent license, and the Corresponding Source of the work is not available for anyone to copy, free of charge and under the terms of this License, through a publicly accessible server or other readily accessible means, then you must either (1) cause the Corresponding Source to be so available, or (2) arrange to deprive yourself of the benefit of the patent license for this particular work, or (3) arrange, in a manner consistent with the requirements of this License, to extend the patent license to downstream recipients. "Knowingly relying" means you have actual knowledge that, for the patent license, your conveying of the work to a recipient, or your offering your recipient's use of the covered work in a country, would infringe one or more identifiable patents in that country that you have reason to believe are valid.

If pursuant to or in connection with a single transaction or arrangement, you convey, or propagate by procuring conveyance of, a covered work, and grant a patent license to some of the parties receiving the covered work or a copy of it, and you also convey, or propagate by procuring conveyance of, the Corresponding Source for the covered work, then the patent license you grant is automatically extended to all recipients of the covered work and works based on it.

A patent license is "discriminatory" if it does not include within the scope of its coverage, prohibits the exercise of, or is conditioned on the non-exercise of one or more of the rights that are specifically granted under this License. You may not convey a covered work if you are a party to an arrangement with a third party that is in the business of distributing software, under which you make payment to the third party based on the extent of your activity of conveying the work, and under which the third party grants, to any of the parties who would receive the covered work from you, a discriminatory patent license (a) in connection with copies of the covered work conveyed by you (or copies made from those copies), or (b) primarily for and in connection with specific products or compilations that contain the covered work, unless you entered into that arrangement, or that patent license was granted, prior to 28 March 2007. Nothing in this License shall be construed as excluding or limiting any implied license or other defenses to infringement that may otherwise be available to you under applicable patent law.

12. No Surrender of Others' Freedom.

If conditions are imposed on you (whether by court order, agreement or otherwise) that contradict the conditions of this License, they do not excuse you from the conditions of this License. If you cannot convey a covered work so as to satisfy simultaneously your obligations under this License and any other applicable obligations, then, as a consequence, you may not convey it at all. For example, if you agree to terms that obligate you to collect a royalty for further conveying from those to whom you convey the Program, the only way you could satisfy both those terms and this License would be to refrain entirely from conveying the Program.

13. Use with the GNU Affero General Public License.

Notwithstanding any other provision of this License, you have permission to link or combine any covered work with a work licensed under version 3 of the GNU Affero General Public License into a single combined work, and to convey the resulting work. The terms of this License will continue to apply to the part which is the covered work, but the special requirements of the GNU Affero General Public License, section 13, concerning interaction through a network will apply to the combination as such.

14. Revised Versions of this License.

The Free Software Foundation may publish revised and/or new versions of the GNU General Public License from time to time. Such new versions will be similar in spirit to the present version, but may differ in detail to address new problems or concerns.

Each version is given a unique version number. If the Program specifies that a certain numbered version of the GNU General Public License "or any later version" applies to it, you have the option of following the terms and conditions either of that numbered version or of any later version published by the Free Software Foundation. If the Program does not specify a version number of the GNU General Public License, you may choose any version ever published by the Free Software Foundation.

If the Program specifies that a proxy can decide which future versions of the GNU General Public License can be used, that proxy's public statement of acceptance of a version permanently authorizes you to choose that version for the Program.

Later license versions may give you additional or different permissions. However, no additional obligations are imposed on any author or copyright holder as a result of your choosing to follow a later version.

15. Disclaimer of Warranty.

THIS IS NO WARRANTY FOR THE PROGRAM, TO THE EXTENT PERMITTED BY APPLICABLE LAW. EXCEPT WHEN OTHERWISE STATED IN WRITING THE COPYRIGHT HOLDERS AND/OR OTHER PARTIES PROVIDE THE PROGRAM "AS IS" WITHOUT WARRANTY OF ANY KIND, EITHER EXPRESSED OR IMPLIED, INCLUDING, BUT NOT LIMITED TO, THE IMPLIED WARRANTIES OF MERCHANTABILITY AND FITNESS FOR A PARTICULAR PURPOSE. THE ENTIRE RISK AS TO THE QUALITY AND PERFORMANCE OF THE PROGRAM IS WITH YOU. SHOULD THE PROGRAM PROVE DEFECTIVE, YOU ASSUME THE COST OF ALL NECESSARY SERVICING, REPAIR OR CORRECTION.

16. Limitation of Liability.
IN NO EVENT UNLESS REQUIRED BY APPLICABLE LAW OR AGREED TO IN WRITING WILL ANY COPYRIGHT HOLDER, OR ANY OTHER PARTY WHO MODIFIES AND/OR CONVEYS THIS PROGRAM AS PERMITTED ABOVE, BE LIABLE TO YOU FOR DAMAGES, INCLUDING ANY GENERAL, SPECIAL, INCIDENTAL OR CONSEQUENTIAL DAMAGES ARISING OUT OF THE USE OR INABILITY TO USE THE PROGRAM (INCLUDING BUT NOT LIMITED TO LOSS OF DATA OR DATA BEING RENDERED INACCURATE OR LOSSES SUSTAINED BY YOU OR THIRD PARTIES OR A FAILURE OF THE PROGRAM TO OPERATE WITH ANY OTHER PROGRAMS), EVEN IF SUCH HOLDER OR OTHER PARTY HAS BEEN ADVISED OF THE POSSIBILITY OF SUCH DAMAGES.

17. Interpretation of Sections 15 and 16.
If the disclaimer of warranty and limitation of liability provided above cannot be given local legal effect according to their terms, reviewing courts shall apply local law that most closely approximates an absolute waiver of all civil liability in connection with the program, unless a warranty or assumption of liability accompanies a copy of the program in return for a fee.

END OF TERMS AND CONDITIONS

How to Apply These Terms to Your New Programs
If you develop a new program, and you want it to be of the greatest possible use to the public, the best way to achieve this is to make it free software which everyone can redistribute and change under these terms.

To do so, attach the following notices to the program. It is safest to attach them to the start of each source file to most effectively state the exclusion of warranty; and each file should have at least the "copyright" line and a pointer to where the full notice is found.

<one line to give the program's name and a brief idea of what it does.>

Copyright (C) <year> <name of author>

This program is free software; you can redistribute it and/or modify it under the terms of the GNU General Public License as published by the Free Software Foundation, either version 3 of the License, or (at your option) any later version.

This program is distributed in the hope that it will be useful, but WITHOUT ANY WARRANTY; without even the implied warranty of MERCHANTABILITY or FITNESS FOR A PARTICULAR PURPOSE. See the GNU General Public License for more details.

You should have received a copy of the GNU General Public License along with this program. If not, see <http://www.gnu.org/licenses/>. Also add information on how to contact you by electronic and paper mail. If the program does terminal interaction, make it output a short notice like this when it starts in an interactive mode:

<program> Copyright (C) <year> <name of author>

This program comes with ABSOLUTELY NO WARRANTY; for details type 'show w'.

This is free software, and you are welcome to redistribute it under certain conditions. Type 'show c' to see these conditions. The hypothetical commands 'show w' and 'show c' should show the appropriate parts of the General Public License. Of course, your program's commands might be different; for a GUI interface, you would use an "about box".

You should also get your employer (if you work as a programmer) or school, if any, to sign a "copyright disclaimer" for the program, if necessary. For more information on this, and how to apply and follow the GNU GPL, see <http://www.gnu.org/licenses/>.

The GNU General Public License does not permit incorporating your program into proprietary programs. If your program is a subroutine library, you may consider it more useful to permit linking proprietary applications with the library. If this is what you want to do, use the GNU Lesser General Public License instead of this License. But first, please read <http://www.gnu.org/philosophy/why-not-lgpl.html>.

GNU LESSER GENERAL PUBLIC LICENSE

Version 2.1, February 1999

Copyright (C) 1991, 1999 Free Software Foundation, Inc.
51 Franklin Street, Fifth Floor, Boston, MA 02110-1301 USA
Everyone is permitted to copy and distribute verbatim copies of this license document, but changing it is not allowed.

[This is the first released version of the Lesser GPL. It also counts as the successor of the GNU Library Public License, version 2, hence the version number 2.1.]

Preamble
The licenses for most software are designed to take away your freedom to share and change it. By contrast, the GNU General Public Licenses are intended to guarantee your freedom to share and change free software—to make sure the software is free for all its users.

This license, the GNU Lesser General Public License, applies to some specially designated software packages—typically libraries—of the Free Software Foundation and other authors who decide to use it. You can use it too, but we suggest you first think carefully about whether this license or the ordinary General Public License is the better strategy to use in any particular case, based on the explanations below.

When we speak of free software, we are referring to freedom of use, not price. Our General Public Licenses are designed to make sure that you have the freedom to distribute copies of free software (and charge for this service if you wish); that you receive source code or can get it if you want it; that you can change the software and use pieces of it in new free programs; and that you are informed that you can do these things.

To protect your rights, we need to make restrictions that forbid distributors to deny you these rights or to ask you to surrender these rights. These restrictions translate to certain responsibilities for you if you distribute copies of the library or if you modify it.

For example, if you distribute copies of the library, whether gratis or for a fee, you must give the recipients all the rights that we gave you. You must make sure that they too, receive or can get the source code. If you link a library with other code, you must provide complete object files to the recipients, so that they can relink them with the library after making changes to the library and recompiling it. And you must show them these terms so they know their rights.

We protect your rights with a two-step method: (1) we copyright the library, and (2) we offer you this license, which gives you legal permission to copy, distribute and/or modify the library.
To protect each distributor, we want to make it very clear that there is no warranty for the free library. Also, if the library is modified by someone else and passed on, the recipients should know that what they have is not the original version, so that the original author's reputation will not be affected by problems that might be introduced by others.

Finally, software patents pose a constant threat to the existence of any free program. We wish to make sure that a company cannot effectively restrict the users of a free program by obtaining a restrictive license from a patent holder. Therefore, we insist that any patent license obtained for a version of the library must be consistent with the full freedom of use specified in this license.

Most GNU software, including some libraries, is covered by the ordinary GNU General Public License. This license, the GNU Lesser General Public License, applies to certain designated libraries, and is quite different from the ordinary General Public License. We use this license for certain libraries in order to permit linking those libraries into non-free programs.

When a program is linked with a library, whether statically or using a shared library, the combination of the two is legally speaking a combined work, a derivative of the original library. The ordinary General Public License therefore permits such linking only if the entire combination fits its criteria of freedom. The Lesser General Public License permits more lax criteria for linking other code with the library.

We call this license the "Lesser" General Public License because it does less to protect the user's freedom than the ordinary General Public License. It also provides other free software developers less of an advantage over competing non-free programs. These disadvantages are the reason we use the ordinary General Public License for many libraries. However, the Lesser License provides advantages in certain special circumstances.

For example, on rare occasions, there may be a special need to encourage the widest possible use of a certain library, so that it becomes a de-facto standard. To achieve this, non-free programs must be allowed to use the library. A more frequent case is that a free library does the same job as widely used non-free libraries. In this case, there is little to gain by limiting the free library to free software only, so we use the Lesser General Public License.

In other cases, permission to use a particular library in non-free programs enables a greater number of people to use a large body of free software. For example, non-free programs use the GNU C library in non-free programs etc. and many more people use the whole GNU operating system, as well as its variant, the GNU/Linux operating system.

Although the Lesser General Public License is less protective of the users' freedom, it does ensure that the user of a program that is linked with the library has the freedom and the wherewithal to run that program using a certain version of the library.

The precise terms and conditions for copying, distribution and modification follow. Pay close attention to the difference between a "work based on the library" and a "work that uses the library". The former contains code derived from the library, whereas the latter must be combined with the library in order to run.

TERMS AND CONDITIONS FOR COPYING, DISTRIBUTION AND MODIFICATION
0. This License Agreement applies to any software library or other program which contains a notice placed by the copyright holder or other authorized party saying it may be distributed under the terms of this Lesser General Public License (also called "this License"). Each licensee is addressed as "you".

A "library" means a collection of software functions and/or data prepared so as to be conveniently linked with application programs (which use those functions and data) to form executables. The "Library", below, refers to any such software library or work which has been distributed under these terms. A "work based on the Library" means either the Library or any derivative work under copyright law; that is to say, a work containing the Library or a portion of it, either verbatim or with modifications and/or translated straightforwardly into another language. (Hereinafter, translation is included without limitation in the term "modification".)

"Source code" for a work means the preferred form of the work for making modifications to it. For a library, complete source code means all the source code for all modules it contains, plus any associated interface definition files, plus the scripts used to control compilation and installation of the library. Activities other than copying, distribution and modification are not covered by this License; they are outside its scope. The act of running a program using the Library is not restricted, and output from such a program is covered only if its contents constitute a work based on the Library (independent of the use of the Library in a tool for writing it). Whether that is true depends on what the Library does and what the program that uses the Library does.

1. You may copy and distribute verbatim copies of the Library's complete source code as you receive it, in any medium, provided that you conspicuously and appropriately publish on each copy an appropriate copyright notice and disclaimer of warranty, keep intact all the notices that refer to this License and to the absence of any warranty, and distribute a copy of this License along with the Library. You may charge a fee for the physical act of transferring a copy, and you may at your option offer warranty protection in exchange for a fee.

2. You may modify your copy or copies of the Library or any portion of it, thus forming a work based on the Library, and copy and distribute such modifications or work under the terms of Section 1 above, provided that you also meet all of these conditions:
a) The modified work must itself be a software library.
b) You must cause the files modified to carry prominent notices stating that you changed the files and the date of any change.
c) You must cause the whole of the work to be licensed at no charge to all third parties under the terms of this License.
d) If a facility in the modified Library refers to a function or a table of data to be supplied by an application program that uses the library, other than as an argument passed when the facility is invoked, then you must make a good faith effort to ensure that, in the event an application does not supply such function or table, the facility still operates, and performs whatever part of its purpose remains meaningful. (For example, a function in a library to compute square roots has a purpose that is entirely well-defined independent of the application. Therefore, Subsection 2d requires that any application-supplied function table used by the function must be optional: if the application does not supply it, the square root function must still compute square roots.)

These requirements apply to the modified work as a whole. If identifiable sections of that work are not derived from the Library, and can be reasonably considered independent and separate works in themselves, then this License, and its terms, do not apply to those sections when you distribute them as separate works. But when you distribute the same sections as part of a whole which is a work based on the Library, the distribution of the whole must be on the terms of this License, whose permissions for other licensees extend to the entire whole, and thus to each and every part regardless of who wrote it. Thus, it is not the intent of this section to claim rights or contest your rights to work written entirely by you; rather, the intent is to exercise the right to control the distribution of derivative or collective works based on the Library.

In addition, mere aggregation of another work not based on the Library (or with a work based on the Library) on a volume of a storage or distribution medium does not bring the other work under the scope of this License.
3. You may opt to apply the terms of the ordinary GNU General Public License instead of this License to a given copy of the Library. To do this, you must alter all the notices that refer to this License, so that they refer to the ordinary GNU General Public License, version 2, instead of to this License. (If a newer version than version 2 of the ordinary GNU General Public License has appeared, then you can specify that version instead of your wish.) Do not make any other change in these notices.
Once this change is made in a given copy, it is irreversible for that copy, so the ordinary GNU General Public License applies to all subsequent copies and derivative works made from that copy. This option is useful when you wish to copy part of the code of the Library into a program that is not a library.
4. You may copy and distribute the Library (or a portion or derivative of it, under Section 2) in object code or executable form under the terms of Sections 1 and 2 above provided that you accompany it with the complete corresponding machine-readable source code, which must be distributed under the terms of Sections 1 and 2 above on a medium customarily used for software interchange.
If distribution and use is made by offering access to copy from a designated place, then offering equivalent access to copy the source code from the same place satisfies the requirement to distribute the source code, even though third parties are not compelled to copy the source along with the object code.
5. A program that contains no derivative of any portion of the Library, but is designed to work with the Library by being compiled or linked with it, is called a "work that uses the Library". Such a work, in object code or executable form, may be distributed under the terms of this License, even if the object code is not a derivative work of the Library, even though the source code is not. Whether this is true is especially significant if the work can be linked without the Library, or if the work is itself a library. The threshold for this to be true is not precisely defined by law.
If such an object file uses only numerical parameters, data structure layouts and accessors, and small macros and small inline functions (ten lines or less in length), then the use of the object file is unrestricted, regardless of whether it is legally a derivative work. (Executables containing this object code plus portions of the Library will still fall under Section 6.)
Otherwise, if the work is a derivative of the Library, you may distribute the object code for the work under the terms of Section 6. Any executables containing that work also fall under Section 6, whether or not they are linked directly with the Library or not.
6. As an exception to the Sections above, you may also combine or link a "work that uses the Library" with the Library to produce a work containing portions of the Library, and distribute that work under terms of your choice, provided that the terms permit modification of the work for the customer's own use and support for that customer's needs.
You must give prominent notice with each copy of the work that the Library is used in it and that the Library and its use are covered by this License. You must supply a copy of this License. If the work during execution displays copyright notices, you must include the copyright notice for the Library among them, as well as a reference directing the user to the copy of this License. Also, you must do one of these things:
a) Accompany the work with the complete corresponding machine-readable source code for the Library, including whatever changes were used in the work (which must be distributed under Sections 1 and 2 above); and, if the work is an executable linked with the Library, with the complete machine-readable "work that uses the Library", as object code and/or source code, so that the user can modify the Library and then relink to produce a modified executable containing the modified Library. (It is understood that the user who changes the contents of definitions outside the Library will not necessarily be able to recompile the application to use the modified definitions.)
b) Use a suitable shared library mechanism for linking with the Library. A suitable mechanism is one that (1) uses at run time a copy of the library already present on the user's computer system, rather than copying library code into the executable, and (2) will operate properly with a modified version of the library, if the user installs one, as long as the modified version is interface-compatible with the version that the work was made with.
c) Accompany the work with a written offer, valid for at least three years, to give the same user the materials specified in Subsection 6a, above, for a charge no more than the cost of performing this service.
d) If distribution of the work is made by offering access to copy from a designated place, offer equivalent access to copy the above specified materials from the same place.
e) Verify that the user has already received a copy of these materials or that you have already sent this user a copy.

7. The copying, distribution and use of the "work that uses the Library" must include any data and utility programs needed for reproducing the executable from it. However, as a special exception, the materials to be distributed need not include anything that is normally distributed (in either source or binary form) with the major components (compiler, kernel, and so on) of the operating system on which the executable runs. This exception does not apply to the work itself if it comes in a form that it is not possible to separate. It may happen that this requirement contradicts the license restrictions of other proprietary libraries that do not normally accompany the operating system. Such a contradiction means you cannot use both them and the Library together in an executable that you distribute.
8. You may place library facilities that are a work based on the Library side-by-side in a single library, and distribute that single library under this license, and distribute that library, provided that the separate distribution of the work based on the Library and of the other library facilities is otherwise permitted, and provided that you do these two things:
a) Accompany the combined library with a copy of the same work based on the Library, uncombined with any other library facilities. This must be distributed under the terms of the Sections above.
b) Give prominent notice with the combined library of the fact that part of it is a work based on the Library, and explaining where to find the accompanying uncombined form of the same work.
9. You may not copy, modify, sublicense, link with, or distribute the Library except as expressly provided under this License. Any attempt otherwise to copy, modify, sublicense, link with, or distribute the Library is void, and will automatically terminate your rights under this License. However, parties who have received copies, or rights, from you under this License will not have their licenses terminated so long as such parties remain in full compliance.
10. You are not required to accept this License, since you have not signed it. However, nothing else grants you permission to modify or distribute the Library or its derivative works. These actions are prohibited by copyright law unless you do not accept this License. Therefore, by modifying or distributing the Library (or any work based on the Library), you indicate your acceptance of this License to do so, and all its terms and conditions for copying, distributing or modifying the Library or works based on it.
11. Each time you redistribute the Library (or any work based on the Library), the recipient automatically receives a license to copy, distribute, link with, or modify the Library subject to these terms and conditions. You may not impose any further restrictions on the recipients' exercise of the rights granted herein. You are not responsible for enforcing compliance by third parties with this License.
12. If, as a consequence of a court judgment or allegation of patent infringement or for any other reason (not limited to patent issues), conditions are imposed on you (whether by court order, agreement or otherwise) that restrict the conditions of the License, they do not excuse you from the conditions of this License. If you cannot distribute so as to satisfy simultaneously your obligations under this License and any other pertinent obligations, then as a consequence you may not distribute the Library at all. For example, if a patent license would not permit royalty-free redistribution of the Library by all those who receive copies directly or indirectly through you, then the only way you could satisfy both it and this License would be to refrain entirely from distribution of the Library.
If any portion of this section is held invalid or unenforceable under any particular circumstance, the balance of the section is intended to apply, and the section as a whole is intended to apply in other circumstances.
13. This section is intended to induce you to infringe any patents or other property right claims or to contest validity of any such claims; this section has the sole purpose of protecting the integrity of the free software distribution system which is implemented by public license practices. Many people have made generous contributions to the wide range of software distributed through this system in reliance on consistent application of that system; it is up to the author/donor to decide if he or she is willing to accept a software patent and to sue, and to indemnify and hold other authors harmless for such patent infringement. This section is intended to make thoroughly clear what is believed to be a consequence of the rest of this License.
14. If the distribution and/or use of the Library is restricted in certain countries either by patents or by copyrighted interfaces, the original copyright holder who places the Library under this License may add an explicit geographical distribution limitation excluding those countries, so that distribution is permitted only

in or among countries not thus excluded. In such case, this License incorporates the limitation as if written in the body of this License.

13. The Free Software Foundation may publish revised and/or new versions of the Lesser General Public License from time to time. Such new versions will be similar in spirit to the present version, but may differ in detail to address new problems or concerns.

Each version is given a distinguishing version number. If the Library specifies a version number of this License which applies to it and "any later version", you have the option of following the terms and conditions either of that version or of any later version published by the Free Software Foundation. If the Library does not specify a license version number, you may choose any version ever published by the Free Software Foundation.

14. If you wish to incorporate parts of the Library into other free programs whose distribution conditions are incompatible with these, write to the author to ask for permission. For software which is copyrighted by the Free Software Foundation, write to the Free Software Foundation; we sometimes make exceptions for this. Our decision will be guided by the two goals of preserving the free status of all derivatives of our free software and of promoting the sharing and reuse of software generally.

NO WARRANTY

15. BECAUSE THE LIBRARY IS LICENSED FREE OF CHARGE, THERE IS NO WARRANTY FOR THE LIBRARY, TO THE EXTENT PERMITTED BY APPLICABLE LAW. EXCEPT WHEN OTHERWISE STATED IN WRITING THE COPYRIGHT HOLDERS AND/OR OTHER PARTIES PROVIDE THE LIBRARY "AS IS" WITHOUT WARRANTY OF ANY KIND, EITHER EXPRESSED OR IMPLIED, INCLUDING, BUT NOT LIMITED TO, THE IMPLIED WARRANTIES OF MERCHANTABILITY AND FITNESS FOR A PARTICULAR PURPOSE. THE ENTIRE RISK AS TO THE QUALITY AND PERFORMANCE OF THE LIBRARY IS WITH YOU. SHOULD THE LIBRARY PROVE DEFECTIVE, YOU ASSUME THE COST OF ALL NECESSARY SERVICING, REPAIR OR CORRECTION.

16. IN NO EVENT UNLESS REQUIRED BY APPLICABLE LAW OR AGREED TO IN WRITING WILL ANY COPYRIGHT HOLDER, OR ANY OTHER PARTY WHO MAY MODIFY AND/OR REVISION THE LIBRARY AS PERMITTED ABOVE, BE LIABLE TO YOU FOR DAMAGES, INCLUDING ANY GENERAL, SPECIAL, INCIDENTAL OR CONSEQUENTIAL DAMAGES ARISING OUT OF THE USE OR INABILITY TO USE THE LIBRARY (INCLUDING BUT NOT LIMITED TO LOSS OF DATA OR DATA BEING RENDERED INACCURATE OR LOSSES SUSTAINED BY YOU OR THIRD PARTIES OR THE FAILURE OF THE LIBRARY TO OPERATE WITH ANY OTHER SOFTWARE), EVEN IF SUCH HOLDER OR OTHER PARTY HAS BEEN ADVISED OF THE POSSIBILITY OF SUCH DAMAGES.

END OF TERMS AND CONDITIONS

How to Apply These Terms to Your New Libraries

If you develop a new library, and you want it to be of the greatest possible use to the public, we recommend making it free software that everyone can redistribute and change. You can do so by permitting redistribution under these terms (or, alternatively, under the terms of the ordinary General Public License).

To apply these terms, attach the following notices to the library. It is safest to attach them to the start of each source file to most effectively convey the exclusion of warranty, and each file should have at least the "copyright" line and a pointer to where the full notice is found.

one line to give the library's name and an idea of what it does.
Copyright (C) year name of author
This library is free software; you can redistribute it and/or modify it under the terms of the GNU Lesser General Public License as published by the Free Software Foundation; either version 2.1 of the License, or (at your option) any later version.

This library is distributed in the hope that it will be useful, but WITHOUT ANY WARRANTY; without even the implied warranty of MERCHANTABILITY or FITNESS FOR A PARTICULAR PURPOSE. See the GNU Lesser General Public License for more details.

You should have received a copy of the GNU Lesser General Public License along with this library; if not, write to the Free Software Foundation, Inc., 51 Franklin Street, Fifth Floor, Boston, MA 02110-1301 USA

Also add information on how to contact you by electronic and paper mail.
You should also get your employer (if you work as a programmer) or your school, if any, to sign a "copyright disclaimer" for the library, if necessary. Here is a sample, alter the names:
Yooyoidc, Inc. hereby dedicates all copyright interest in the library "Frob" (a library for tweaking knobs) written by James Random Hacker.

Signature of Ty Coon, 1 April 1990
Ty Coon, President of Vice
That's all there is to it!
Apache License
Version 2.0, January 2004
<http://www.apache.org/licenses/>

TERMS AND CONDITIONS FOR USE, REPRODUCTION, AND DISTRIBUTION

1. Definitions.
"License" shall mean the terms and conditions for use, reproduction, and distribution as defined by Sections 1 through 9 of this document.
"Licensor" shall mean the copyright owner or entity authorized by the copyright owner that is granting the License.

"Legal Entity" shall mean the union of the acting entity and all other entities that control, are controlled by, or are under common control with that entity. For the purposes of this definition, "control" means (i) the power, direct or indirect, to cause the direction or management of such entity, whether by contract or otherwise, or (ii) ownership of fifty percent (50%) or more of the outstanding shares, or (iii) beneficial ownership of such entity.

"You" (or "Your") shall mean an individual or Legal Entity exercising permissions granted by this License.
"Source" form shall mean the preferred form for making modifications, including but not limited to software source code, documentation, and configuration files.
"Object" form shall mean any form resulting from mechanical transformation or translation of a Source form, including but not limited to compiled object code, generated documentation, and conversions to other media types.

"Work" shall mean the work of authorship, whether in Source or Object form, made available under the License, as indicated by a copyright notice that is included in or attached to the work (an example is provided in the Appendix below).

"Derivative Works" shall mean any work, whether in Source or Object form, that is based on (or derived from) the Work and for which the editorial revisions, annotations, elaborations, or other modifications represent, as a whole, an original work of authorship. For the purposes of this definition, Derivative Works shall not include works that remain separable from, or merely link (or bind by name) to the interfaces of, the Work and Derivative Works thereof.

"Contribution" shall mean any work of authorship, including the original version of the Work and any modifications or additions to that work or Derivative Works thereof, that is intentionally submitted to Licensor for inclusion in the Work by the copyright owner or by an individual or Legal Entity authorized to submit on behalf of the copyright owner. For the purposes of this definition, "submitted" means any form of electronic, verbal, or written communication sent to the Licensor or its representatives, including but not limited to communication on electronic mailing lists, source code control systems, and issue tracking systems that are supported by the Licensor for the purpose of discussing and improving the Work, but excluding communication that is conspicuously marked or otherwise designated in writing by the copyright owner as "Not a Contribution."

"Contributor" shall mean Licensor and any individual or Legal Entity on behalf of whom a Contribution has been received by Licensor and subsequently incorporated within the Work.

2. Grant of Copyright License. Subject to the terms and conditions of this License, each Contributor hereby grants to You a perpetual, worldwide, non-exclusive, no-charge, royalty-free, irrevocable copyright license to reproduce, prepare Derivative Works of, publicly display, publicly perform, sublicense, and distribute the Work and such Derivative Works in Source or Object form.

3. Grant of Patent License. Subject to the terms and conditions of this License, each Contributor hereby grants to You a perpetual, worldwide, non-exclusive, no-charge, royalty-free, irrevocable (except as stated in this section) patent license to make, have made, use, offer to sell, sell, import, and otherwise transfer the Work, where such license applies only to those patent claims licensable by such Contributor that are necessarily infringed by their Contribution(s) alone or by combination of their Contribution(s) with the Work to which such Contribution(s) was submitted. If You institute patent litigation against any entity (including a cross-claim or counterclaim in a lawsuit) alleging that the Work or a Contribution incorporated within the Work constitutes direct or contributory patent infringement, then any patent licenses granted to You under this License for that Work shall terminate as of the date such litigation is filed.

4. Redistribution. You may reproduce and distribute copies of the Work or Derivative Works thereof in any medium, with or without modifications, and in Source or Object form, provided that You meet the following conditions:

1. You must give any other recipients of the Work or Derivative Works a copy of this License; and
2. You must cause any modified files to carry prominent notices stating that You changed the files; and
3. You must retain, in the Source form of any Derivative Works that You distribute, all copyright, patent, trademark, and attribution notices from the Source form of the Work, excluding those notices that do not pertain to any part of the Derivative Works; and

4. If the Work includes a "NOTICE" text file as part of its distribution, then any Derivative Works that You distribute must include a readable copy of the attribution notices contained within such NOTICE file, excluding those notices that do not pertain to any part of the Derivative Works, in at least one of the following places: within a NOTICE text file distributed as part of the Derivative Works; within the Source form or documentation, if provided along with the Derivative Works; or, within a display generated by the Derivative Works, if and wherever such third-party notices normally appear. The contents of the NOTICE file are for informational purposes only and do not modify the License. You may add Your own attribution notices within Derivative Works that You distribute, alongside or as an addendum to the NOTICE text from the Work, provided that such additional attribution notices cannot be construed as modifying the License.

5. Submission of Contributions. Unless You explicitly state otherwise, any Contribution intentionally submitted for inclusion in the Work by You to the Licensor shall be under the terms and conditions of this License, without any additional terms or conditions. Notwithstanding the above, nothing herein shall supersede or modify the terms of any separate license agreement you may have executed with Licensor regarding such Contributions.

6. Trademarks. This License does not grant permission to use the trade names, trademarks, service marks, or product names of the Licensor, except as required for reasonable and customary use in describing the origin of the Work and reproducing the content of the NOTICE file.

7. Disclaimer of Warranty. Unless required by applicable law or agreed to in writing, Licensor provides the Work (and each Contributor provides its Contributions) on an "AS IS" BASIS, WITHOUT WARRANTIES OR CONDITIONS OF ANY KIND, either express or implied, including, without limitation, any warranties or conditions of TITLE, NON-INFRINGEMENT, MERCHANTABILITY, or FITNESS FOR A PARTICULAR PURPOSE. You are solely responsible for determining the appropriateness of using or redistributing the Work and assuming any risks associated with Your exercise of permissions under this License.

8. Limitation of Liability. In no event and under no legal theory, whether in tort (including negligence), contract, or otherwise, unless required by applicable law (such as deliberate and grossly negligent acts) or agreed to in writing, shall any Contributor be liable to You for damages, including any direct, indirect, special, incidental, or consequential damages arising out of the use or inability to use the Work (including but not limited to damages for loss of goodwill, work stoppage, computer failure or malfunction, or any and all other commercial damages or losses), even if such Contributor has been advised of the possibility of such damages.

9. Accepting Warranty or Additional Liability. While redistributing the Work or Derivative Works thereof, you may choose to offer, and charge a fee for, acceptance of support, warranty, indemnity, or other liability obligations and/or rights consistent with this License. However, in accepting such obligations, you may act only on Your own behalf and on Your sole responsibility, not on behalf of any other Contributor, and only if You agree to indemnify, defend, and hold each Contributor harmless for any liability incurred by, or claims asserted against, such Contributor by reason of your accepting any such warranty or additional liability.

END OF TERMS AND CONDITIONS

APPENDIX: How to apply the Apache License to your work
To apply the Apache License to your work, attach the following boilerplate notice, with the fields enclosed by brackets replaced with your own identifying information. (Don't include the brackets!) The text should be enclosed in the appropriate comment syntax for the file format. We also recommend that a file or class name and description of purpose be included on the same "printed page" as the copyright notice for easier identification within third-party archives.

Copyright [yyyy] [name of copyright owner]
Licensed under the Apache License, Version 2.0 (the "License");
you may not use this file except in compliance with the License.
You may obtain a copy of the License at
<http://www.apache.org/licenses/LICENSE-2.0>

Unless required by applicable law or agreed to in writing, software distributed under the License is distributed on an "AS IS" BASIS, WITHOUT WARRANTIES OR CONDITIONS OF ANY KIND, either express or implied. See the License for the specific language governing permissions and limitations under the License.

Copyright (c) 1989, 1991, 1993, 1994 The Regents of the University of California.
All rights reserved.
This code is derived from software contributed to Berkeley by Kenneth Alquist
Redistribution and use in source and binary forms, with or without modification, are permitted provided that the following conditions are met:

1.Redistributions of source code must retain the above copyright notice, this list of conditions and the following disclaimer.
2.Redistributions in binary form must reproduce the above copyright notice, this list of conditions and the following disclaimer in the documentation and/or other materials provided with the distribution.
3.Neither the name of the University nor the names of its contributors may be used to endorse or promote products derived from this software without specific prior written permission.

THIS SOFTWARE IS PROVIDED BY THE REGENTS AND CONTRIBUTORS "AS IS" AND ANY EXPRESS OR IMPLIED WARRANTIES, INCLUDING, BUT NOT LIMITED TO, THE IMPLIED WARRANTIES OF MERCHANTABILITY AND FITNESS FOR A PARTICULAR PURPOSE ARE DISCLAIMED. IN NO EVENT SHALL THE REGENTS OR CONTRIBUTORS BE LIABLE FOR ANY DIRECT, INDIRECT, INCIDENTAL, SPECIAL, EXEMPLARY, OR CONSEQUENTIAL DAMAGES (INCLUDING, BUT NOT LIMITED TO, PROCUREMENT OF SUBSTITUTE GOODS OR SERVICES; LOSS OF USE, DATA, OR PROFITS; OR BUSINESS INTERRUPTION) HOWEVER CAUSED AND ON ANY THEORY OF LIABILITY, WHETHER IN CONTRACT, STRICT LIABILITY, OR TORT (INCLUDING NEGLIGENCE OR OTHERWISE) ARISING IN ANY WAY OUT OF THE USE OF THIS SOFTWARE, EVEN IF ADVISED OF THE POSSIBILITY OF SUCH DAMAGE.

telnet-server license
Copyright (c) 2005-2009, Thomas BERNARD
All rights reserved.
Redistribution and use of this software in source and binary forms, with or without modification, are permitted provided that the following conditions are met:

1.Redistributions of source code must retain the above copyright notice, this list of conditions and the following disclaimer.
2.Redistributions in binary form must reproduce the above copyright notice, this list of conditions and the following disclaimer in the documentation and/or other materials provided with the distribution.
3.All advertising materials mentioning features or use of this software must display the following acknowledgment:

This product includes software developed by the University of California, Berkeley and its contributors.
4.Neither the name of the University nor the names of its contributors may be used to endorse or promote products derived from this software without specific prior written permission.

THIS SOFTWARE IS PROVIDED BY THE COPYRIGHT HOLDERS AND CONTRIBUTORS "AS IS" AND ANY EXPRESS OR IMPLIED WARRANTIES, INCLUDING, BUT NOT LIMITED TO, THE IMPLIED WARRANTIES OF MERCHANTABILITY AND FITNESS FOR A PARTICULAR PURPOSE ARE DISCLAIMED. IN NO EVENT SHALL THE COPYRIGHT OWNER OR CONTRIBUTORS BE LIABLE FOR ANY DIRECT, INDIRECT, INCIDENTAL, SPECIAL, EXEMPLARY, OR CONSEQUENTIAL DAMAGES (INCLUDING, BUT NOT LIMITED TO, PROCUREMENT OF SUBSTITUTE GOODS OR SERVICES; LOSS OF USE, DATA, OR PROFITS; OR BUSINESS INTERRUPTION) HOWEVER CAUSED AND ON ANY THEORY OF LIABILITY, WHETHER IN CONTRACT, STRICT LIABILITY, OR TORT (INCLUDING NEGLIGENCE OR OTHERWISE) ARISING IN ANY WAY OUT OF THE USE OF THIS SOFTWARE, EVEN IF ADVISED OF THE POSSIBILITY OF SUCH DAMAGE.

YUI License
Copyright (c) 2011, Yahoo! Inc.
All rights reserved.
Redistribution and use of this software in source and binary forms, with or without modification, are permitted provided that the following conditions are met:

1.Redistributions of source code must retain the above copyright notice, this list of conditions and the following disclaimer.
2.Redistributions in binary form must reproduce the above copyright notice, this list of conditions and the following disclaimer in the documentation and/or other materials provided with the distribution.
3.All advertising materials mentioning features or use of this software must display the following acknowledgment:

This product includes software developed by the University of California, Berkeley and its contributors.
4.Neither the name of the University nor the names of its contributors may be used to endorse or promote products derived from this software without specific prior written permission.

THIS SOFTWARE IS PROVIDED BY THE COPYRIGHT HOLDERS AND CONTRIBUTORS "AS IS" AND ANY EXPRESS OR IMPLIED WARRANTIES, INCLUDING, BUT NOT LIMITED TO, THE IMPLIED WARRANTIES OF MERCHANTABILITY AND FITNESS FOR A PARTICULAR PURPOSE ARE DISCLAIMED. IN NO EVENT SHALL THE COPYRIGHT OWNER OR CONTRIBUTORS BE LIABLE FOR ANY DIRECT, INDIRECT, INCIDENTAL, SPECIAL, EXEMPLARY, OR CONSEQUENTIAL DAMAGES (INCLUDING, BUT NOT LIMITED TO, PROCUREMENT OF SUBSTITUTE GOODS OR SERVICES; LOSS OF USE, DATA, OR PROFITS; OR BUSINESS INTERRUPTION) HOWEVER CAUSED AND ON ANY THEORY OF LIABILITY, WHETHER IN CONTRACT, STRICT LIABILITY, OR TORT (INCLUDING NEGLIGENCE OR OTHERWISE) ARISING IN ANY WAY OUT OF THE USE OF THIS SOFTWARE, EVEN IF ADVISED OF THE POSSIBILITY OF SUCH DAMAGE.

ppp license
Copyright (c) 1993 The Australian National University.
All rights reserved.
Redistribution and use in source and binary forms are permitted provided that the above copyright notice and this paragraph are included in all such forms and that any documentation, advertising materials, and other materials related to such distribution and use acknowledge that the software was developed by the Australian National University. The name of the University may not be used to endorse or promote products derived from this software without specific prior written permission.

THIS SOFTWARE IS PROVIDED "AS IS" AND WITHOUT ANY EXPRESS OR IMPLIED WARRANTIES, INCLUDING, WITHOUT LIMITATION, THE IMPLIED WARRANTIES OF MERCHANTABILITY AND FITNESS FOR A PARTICULAR PURPOSE.

Copyright (c) 1989 Carnegie Mellon University.
All rights reserved.
Redistribution and use in source and binary forms are permitted provided that the above copyright notice and this paragraph are included in all such forms and that any documentation, advertising materials, and other materials related to such distribution and use acknowledge that the software was developed by Carnegie Mellon University. The name of the University may not be used to endorse or promote products derived from this software without specific prior written permission.

THIS SOFTWARE IS PROVIDED "AS IS" AND WITHOUT ANY EXPRESS OR IMPLIED WARRANTIES, INCLUDING, WITHOUT LIMITATION, THE IMPLIED WARRANTIES OF MERCHANTABILITY AND FITNESS FOR A PARTICULAR PURPOSE.

c-res license
Copyright 1998 by the Massachusetts Institute of Technology.
Permission to use, copy, modify, and distribute this software and its documentation for any purpose and

without fee is hereby granted, provided that the above copyright notice appear in all copies and that both that copyright notice and this permission notice appear in supporting documentation, and that the name of M.I.T. not be used in advertising or publicity pertaining to distribution of the software without specific, written prior permission.

M.I.T. makes no representations about the suitability of this software for any purpose. It is provided "as is" without express or implied warranty.

curl license:

Copyright (c) 1996 - 2010, Daniel Stenberg, <daniel@haxx.se>.
All rights reserved.

Permission to use, copy, modify, and distribute this software for any purpose with or without fee is hereby granted, provided that the above copyright notice and this permission notice appear in all copies. THE SOFTWARE IS PROVIDED "AS IS", WITHOUT WARRANTY OF ANY KIND, EXPRESS OR IMPLIED, INCLUDING BUT NOT LIMITED TO THE WARRANTIES OF MERCHANTABILITY, FITNESS FOR A PARTICULAR PURPOSE AND NONINFRINGEMENT OF THIRD PARTY RIGHTS. IN NO EVENT SHALL THE AUTHORS OR COPYRIGHT HOLDERS BE LIABLE FOR ANY CLAIM, DAMAGES OR OTHER LIABILITY, WHETHER IN AN ACTION OF CONTRACT, TORT OR OTHERWISE, ARISING FROM, OUT OF OR IN CONNECTION WITH THE SOFTWARE OR THE USE OR OTHER DEALINGS IN THE SOFTWARE.

Except as contained in this notice, the name of a copyright holder shall not be used in advertising or otherwise to promote the sale, use or other dealings in this Software without prior written authorization of the copyright holder.

liboath license:

Copyright 2007, 2008 Robin Gareus <robin@gareus.org>

Unless otherwise indicated, Source Code is licensed under MIT license.

Permission is hereby granted, free of charge, to any person obtaining a copy of this software and associated documentation files (the "Software"), to deal in the Software without restriction, including without limitation the rights to use, copy, modify, merge, publish, distribute, sublicense, and/or sell copies of the Software, and to permit persons to whom the Software is furnished to do so, subject to the following conditions:

The above copyright notice and this permission notice shall be included in all copies or substantial portions of the Software.

THE SOFTWARE IS PROVIDED "AS IS", WITHOUT WARRANTY OF ANY KIND, EXPRESS OR IMPLIED, INCLUDING BUT NOT LIMITED TO THE WARRANTIES OF MERCHANTABILITY, FITNESS FOR A PARTICULAR PURPOSE AND NONINFRINGEMENT OF THIRD PARTY RIGHTS. IN NO EVENT SHALL THE AUTHORS OR COPYRIGHT HOLDERS BE LIABLE FOR ANY CLAIM, DAMAGES OR OTHER LIABILITY, WHETHER IN AN ACTION OF CONTRACT, TORT OR OTHERWISE, ARISING FROM, OUT OF OR IN CONNECTION WITH THE SOFTWARE OR THE USE OR OTHER DEALINGS IN THE SOFTWARE.

jpeg license:

Copyright (c) 2011 The jpeg project. <<http://code.google.com/p/jpeg/>>

Permission is hereby granted, free of charge, to any person obtaining a copy of this software and associated documentation files (the "Software"), to deal in the Software without restriction, including without limitation the rights to use, copy, modify, merge, publish, distribute, sublicense, and/or sell copies of the Software, and to permit persons to whom the Software is furnished to do so, subject to the following conditions:

The above copyright notice and this permission notice shall be included in all copies or substantial portions of the Software.

THE SOFTWARE IS PROVIDED "AS IS", WITHOUT WARRANTY OF ANY KIND, EXPRESS OR IMPLIED, INCLUDING BUT NOT LIMITED TO THE WARRANTIES OF MERCHANTABILITY, FITNESS FOR A PARTICULAR PURPOSE AND NONINFRINGEMENT OF THIRD PARTY RIGHTS. IN NO EVENT SHALL THE AUTHORS OR COPYRIGHT HOLDERS BE LIABLE FOR ANY CLAIM, DAMAGES OR OTHER LIABILITY, WHETHER IN AN ACTION OF CONTRACT, TORT OR OTHERWISE, ARISING FROM, OUT OF OR IN CONNECTION WITH THE SOFTWARE OR THE USE OR OTHER DEALINGS IN THE SOFTWARE.

OpenSSL license:

Copyright (c) 1998-2011 The OpenSSL Project. All rights reserved.

Redistribution and use in source and binary forms, with or without modification, are permitted provided that the following conditions are met:

1.Redistributions of source code must retain the above copyright notice, this list of conditions and the following disclaimer.
2.Redistributions in binary form must reproduce the above copyright notice, this list of conditions and the following disclaimer in the documentation and/or other materials provided with the distribution.
3.All advertising materials mentioning features or use of this software must display the following acknowledgment:

"This product includes software developed by the OpenSSL Project for use in the OpenSSL Toolkit. (<http://www.openssl.org/>)"

4.The names "OpenSSL Toolkit" and "OpenSSL Project" must not be used to endorse or promote products derived from this software without prior written permission. For written permission, please contact openssl-core@openssl.org.

5.Products derived from this software may not be called "OpenSSL" nor may "OpenSSL" appear in their names without prior written permission of the OpenSSL Project.

6.Redistributions of any form whatsoever must retain the following acknowledgment:

"This product includes software developed by the OpenSSL Project for use in the OpenSSL Toolkit (<http://www.openssl.org/>)"

THIS SOFTWARE IS PROVIDED BY THE OPENSSL PROJECT "AS IS" AND ANY EXPRESSED OR IMPLIED WARRANTIES, INCLUDING, BUT NOT LIMITED TO, THE IMPLIED WARRANTIES OF MERCHANTABILITY AND FITNESS FOR A PARTICULAR PURPOSE ARE DISCLAIMED. IN NO EVENT SHALL THE OPENSSL PROJECT OR ITS CONTRIBUTORS BE LIABLE FOR ANY DIRECT, INDIRECT, INCIDENTAL, SPECIAL, EXEMPLARY OR CONSEQUENTIAL DAMAGES (INCLUDING, BUT NOT LIMITED TO, PROCUREMENT OF SUBSTITUTE GOODS OR SERVICES; LOSS OF USE, DATA, OR PROFITS; OR BUSINESS INTERRUPTION) HOWEVER CAUSED AND ON ANY THEORY OF LIABILITY, WHETHER IN CONTRACT, STRICT LIABILITY, OR TORT (INCLUDING NEGLIGENCE OR OTHERWISE) ARISING IN ANY WAY OUT OF THE USE OF THIS SOFTWARE, EVEN IF ADVISED OF THE POSSIBILITY OF SUCH DAMAGE.

This product includes cryptographic software written by Eric Young (eay@cryptsoft.com). This product includes software written by Tim Hudson (tjh@cryptsoft.com).

Original SSLeay License

Copyright (C) 1995-1998 Eric Young (eay@cryptsoft.com)

All rights reserved.

This package is an SSL implementation written by Eric Young (eay@cryptsoft.com).

The implementation was written so as to conform with Netscapes SSL.

This library is free for commercial and non-commercial use as long as the following conditions are adhered to. The following conditions apply to all code found in this distribution, be it the RC4, RSA, lhash, DES, etc. code; not just the SSL code. The SSL documentation included with this distribution is covered by the same copyright terms except that the holder is Tim Hudson (tjh@cryptsoft.com).

Copyright remains Eric Young's, and as such any Copyright notices in the code are not to be removed. If this package is used in a product, Eric Young should be given attribution as the author of the parts of the library used. This can be in the form of a textual message at program startup or in documentation (online or textual) provided with the package.

Redistribution and use in source and binary forms, with or without modification, are permitted provided that the following conditions are met.

1.Redistributions of source code must retain the copyright notice, this list of conditions and the following disclaimer.

2.Redistributions in binary form must reproduce the above copyright notice, this list of conditions and the following disclaimer in the documentation and/or other materials provided with the distribution.

3.All advertising materials mentioning features or use of this software must display the following acknowledgment:

"This product includes cryptographic software written by Eric Young (eay@cryptsoft.com)"

The word "cryptographic" can be left out if the routines from the library being used are not cryptographic related :-).

4.If you include any Windows specific code (or a derivative thereof) from the apps directory (application code) you must include an acknowledgment:

"This product includes software written by Tim Hudson (tjh@cryptsoft.com)"

THIS SOFTWARE IS PROVIDED BY ERIC YOUNG "AS IS" AND ANY EXPRESS OR IMPLIED WARRANTIES, INCLUDING, BUT NOT LIMITED TO, THE IMPLIED WARRANTIES OF MERCHANTABILITY AND FITNESS FOR A PARTICULAR PURPOSE ARE DISCLAIMED. IN NO EVENT SHALL THE AUTHOR OR CONTRIBUTORS BE LIABLE FOR ANY DIRECT, INDIRECT, INCIDENTAL, SPECIAL, EXEMPLARY, OR CONSEQUENTIAL DAMAGES (INCLUDING, BUT NOT LIMITED TO, PROCUREMENT OF SUBSTITUTE GOODS OR SERVICES; LOSS OF USE, DATA, OR PROFITS, OR BUSINESS INTERRUPTION) HOWEVER CAUSED AND ON ANY THEORY OF LIABILITY, WHETHER IN CONTRACT, STRICT LIABILITY, OR TORT (INCLUDING NEGLIGENCE OR OTHERWISE) ARISING IN ANY WAY OUT OF THE USE OF THIS SOFTWARE, EVEN IF ADVISED OF THE POSSIBILITY OF SUCH DAMAGE.

The licence and distribution terms for any publically available version or derivative of this code cannot be changed. i.e. this code cannot simply be copied and put under another distribution licence (including the GNU Public Licence).

SIL OPEN FONT LICENSE
Version 1.1 - 26 February 2007

PREAMBLE

The goals of the Open Font License (OFL) are to stimulate worldwide development of collaborative font projects, to support the font creation efforts of academic and linguistic communities, and to provide a free and open framework in which fonts may be shared and improved in partnership with others.

The OFL allows the licensed fonts to be used, studied, modified and redistributed freely as long as they are not sold by themselves. The fonts, including any derivative works, can be bundled, embedded, redistributed and/or sold with any software provided that any reserved names are not used by derivative works. The fonts and derivatives, however, cannot be released under any other type of license. The requirement for fonts to remain under this license does not apply to any document created using the fonts or their derivatives.

"Font Software" refers to the set of files released by the Copyright Holder(s) under this license and clearly marked as such. This may include source files, build scripts and documentation.

"Reserved Font Name" refers to any names specified as such after the copyright statement(s).

"Original Version" refers to the collection of Font Software components as distributed by the Copyright Holder(s).

"Modified Version" refers to any derivative made by adding to, deleting, or substituting — in part or in whole — any of the components of the Original Version, by changing formats or by porting the Font Software to a new environment.

"Author" refers to any designer, engineer, programmer, technical writer or other person who contributed to the Font Software.

PERMISSION & CONDITIONS

Permission is hereby granted, free of charge, to any person obtaining a copy of the Font Software, to use, study, copy, merge, embed, modify, redistribute, and sell modified and unmodified copies of the Font Software, subject to the following conditions:

1) Neither the Font Software nor any of its individual components, in Original or Modified Versions, may be sold by itself.

2) Original or Modified Versions of the Font Software may be bundled, redistributed and/or sold with any software, provided that each copy contains the above copyright notice and this license. These can be included either as stand-alone text files, human-readable headers or in the appropriate machine-readable metadata fields within text or binary files as long as those fields can be easily viewed by the user.

3) No Modified Version of the Font Software may use the Reserved Font Name(s) unless explicit written permission is granted by the corresponding Copyright Holder. This restriction only applies to the primary font name as presented to the users.

4) The name(s) of the Copyright Holder(s) or the Author(s) of the Font Software shall not be used to promote, endorse or advertise any Modified Version, except to acknowledge the contribution(s) of the Copyright Holder(s) and the Author(s) or with their explicit written permission.

5) The Font Software, modified or unmodified, in part or in whole, must be distributed entirely under this license, and must not be distributed under any other license. The requirement for fonts to remain under this license does not apply to any document created using the Font Software.

TERMINATION

This license becomes null and void if any of the above conditions are not met.

DISCLAIMER

THE FONT SOFTWARE IS PROVIDED "AS IS", WITHOUT WARRANTY OF ANY KIND, EXPRESS OR IMPLIED, INCLUDING BUT NOT LIMITED TO ANY WARRANTIES OF MERCHANTABILITY, FITNESS FOR A PARTICULAR PURPOSE AND NONINFRINGEMENT OF COPYRIGHT, PATENT, TRADEMARK, OR OTHER RIGHT. IN NO EVENT SHALL THE COPYRIGHT HOLDER BE LIABLE FOR ANY CLAIM, DAMAGES OR OTHER LIABILITY, INCLUDING ANY GENERAL, SPECIAL, INDIRECT, INCIDENTAL, OR CONSEQUENTIAL DAMAGES, WHETHER IN AN ACTION OF CONTRACT, TORT OR OTHERWISE, ARISING FROM, OUT OF THE USE OR INABILITY TO USE THE FONT SOFTWARE OR FROM OTHER DEALINGS IN THE FONT SOFTWARE.

Manufacturer might service at user's cost for following request made by customer.

1. Customer notice.

- ✓ Please make regular schedule to check unit status (Daily check is recommended).
- ✓ Manufacturer will not take any responsibility on the physical/human damage caused by robbery, natural disaster.
- ✓ A/S will include product only manufactured by original manufacturer.
- ✓ Any damage caused during installation will be dealt with installation company.
- ✓ Manufacturer doesn't take any responsibility on wrong specified feature excluded in product manual or described improperly by other shopping mall.
- ✓ Please make sure to backup recorded data as recorded data will be removed while manufacturer repair the unit. Manufacturer will not be responsible for any data loss caused during repair service.

2. Service request for product usage.

- ✓ Service request on signal check according to usage environment, power check, network setting.

3. Installation or explanation request on external device to be integrated with this product.

4. Simple assemble or disassemble, adjustment and any request for S/W upgrade.

- ✓ Service request for any damage caused by other stuff coming into device.
- ✓ In case of simple adjustment without disassemble.
- ✓ Just for S/W upgrade (not for product repair)

5. Others

- ✓ Any damage comes from carelessness of customer or explanation request for usage.
(Please contact manufacturer for consumable parts)
- ✓ Any damage comes from wrong media use and service request for this.
- ✓ Any damage comes from wrong installation.

※ We recommend for user to contact (☎+82-1644-3421) before claiming customer service since customer service will require certain amount of cost.

Warranty

Product name	Digital Video Recorder	Warranty term
Model name	HD1600F-R / HD1600F-PDR HDC1601M / HD801F-PD HDC801H / HDC400F-PD HDC400F	2 years after purchase
Date of purchase	/ /	
Warranty term	/ /	
Serial number		

Customer's address	Name	
	Contact	
Address of shop(Company name)	Name	
	Contact	

◆ Please fill out vacant area before selling products.

★ For customer service ★

Please read through product manual before claiming customer service.

Any simple malfunctions due to customer's misunderstanding on the product will be fixed by customer's side.

For requesting service?

Please inform details of malfunctions correctly.

Free or non free repair will be decided based on details of warranty card.

WebGate Division Daemyung Enterprise Co., Ltd.

6F Hanlim Venture Town B/D 689-6, Geumjeong Dong, Gunposi, Gyeonggido, Korea

Main : TEL : +82-31-428-9300

Client Service : TEL : +82-1644-3421

The damage coming from following condition will be repaired at customer's cost.

- 1) Any damage comes from customer's carelessness.
- 2) In case not recommended power is entered.
- 3) In case user repair unit at their own.
- 4) Any damage comes from natural disaster (Fire, Flood, etc)
- 5) Consumable parts replacement.



The World's first certified by
HDcctv Alliance

Premium to your **HD-CCTV**

WEBGATE

WEBGATE Div. Daemyung Enterprise Co., Ltd.

TEL +82-31-428-9300
sales@webgateinc.com
support@webgateinc.com
www.webgateinc.com